

CAMERA POLE MOUNTING BRACKET

C-BC771PM

Thank you for purchasing TOA's Camera Pole Mounting Bracket. Please carefully follow the instructions in this manual to ensure long, trouble-free use of your equipment.

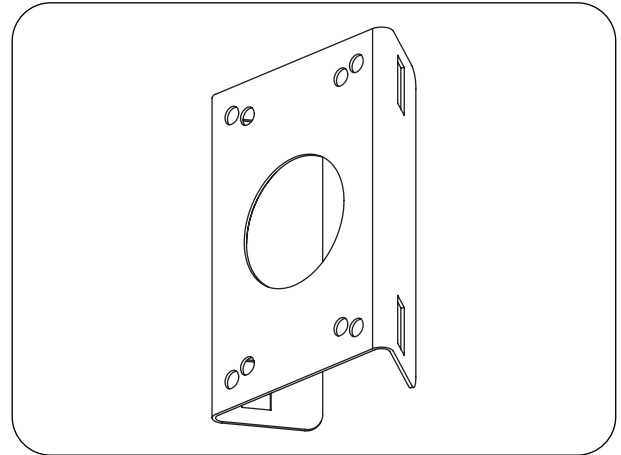

1. SAFETY PRECAUTIONS

- Be sure to read the instructions in this section carefully before use.
- Make sure to observe the instructions in this manual as the conventions of safety symbols and messages regarded as very important precautions are included.
- We also recommend you keep this instruction manual handy for future reference.



WARNING

Indicates a potentially hazardous situation which, if mishandled, could result in death or serious personal injury.

When Installing the Unit

- Install the unit only in a location that can structurally support the weight of the unit and the ceiling suspension bracket. Doing otherwise may result in the unit falling down and causing personal injury and/or property damage.
- Do not install the unit in the following locations to avoid a traffic accident or personal injury:
 - Locations which block the driving of a car or somebody's passage.
 - Locations where the traffic signal or road sign is hard to be seen.
- Avoid installing or mounting the unit in unstable locations, such as on a rickety table or a slanted surface. Doing so may result in the unit falling down and causing personal injury and/or property damage.
- Use the dedicated mounting bracket. The unit could fall off, possibly resulting in personal injuries when other bracket than dedicated is used.



WARNING

Indicates a potentially hazardous situation which, if mishandled, could result in death or serious personal injury.

When Installing the Unit

- Do not use any methods other than specified to mount the bracket. Extreme force is applied to the unit and the unit could fall off, possibly resulting in personal injuries.
- Attach the safety wire to the unit. If not attached, the unit could fall off, resulting in personal injury.
- Use nuts and bolts that are appropriate for the ceiling's or wall's structure and composition. Failure to do so may cause the unit to fall, resulting in material damage and possible personal injury.
- Tighten each nut and bolt securely. Ensure that the bracket has no loose joints after installation to prevent accidents that could result in personal injury.
- Avoid installing the unit in locations exposed to sea breeze or corrosive gas. Mounts may become corroded, eventually causing the unit to fall off, which could result in personal injury.
- Do not mount the unit in locations exposed to constant vibration. The mounting screws and/or bolts may be loosened by excessive vibration, potentially causing the unit to fall, which could result in personal injury.
- To prevent lightning strikes, install the unit at least five meters away from a lightning rod, and yet within the protective range (angle of 45°) of the lightning conductor. Lightning strikes may cause a fire, electric shock or personal injury.
- When installing the unit in the snowy area, take appropriate measures to prevent snow from lying on the unit. If the snow lies on the unit, the unit may fall, causing personal injuries.
- Be sure that at least two persons are available to install the unit. Failure to do so could result in personal injury.
- Avoid installing the unit at heights exceeding 16 meters above the ground since the unit could be exposed to unexpected strong winds that might cause it to fall or result in other accidents.

When the Unit is in Use

- Do not touch the unit during thunder and lightning, as this may result in electric shock.



CAUTION

Indicates a potentially hazardous situation which, if mishandled, could result in moderate or minor personal injury, and/or property damage.

When Installing the Unit

- Refer all installation work to the dealer from whom the unit was purchased. Installation requires extensive technical knowledge and experience. Failure to do so may cause electric shocks or personal injury.
- To avoid electric shocks, be sure to switch off the power before power supply wiring work.

When the Unit is in Use

- Do not stand or sit on, nor hang down from the unit as this may cause it to fall down or drop, resulting in personal injury and/or property damage.
- Have the unit checked periodically by the shop from where it was purchased. Failure to do so may result in corrosion or damage to the unit or its mounting brackets that could cause the unit to fall, possibly causing personal injury.

2. GENERAL DESCRIPTION

The C-BC771PM Camera Pole Mounting Bracket is designed to mount TOA Outdoor Combination Camera C-CC714, C-CC764 or C-CC774 on a pole in conjunction with the C-BC711W Wall Mounting Bracket for the Outdoor Combination Camera and the YS-60B Mounting Band. It also permits the C-CC704 Combination Camera to be mounted on a pole in conjunction with the C-BC704W Camera Wall Mounting Bracket and the YS-60B Mounting Band.

3. HANDLING PRECAUTIONS

- When mounting the units to a pole, pay special attention to the sway and strength of the pole, and mount it securely at an appropriate height that will not cause the pole to sway and possibly weaken it. Moreover, avoid mounting the units to a pole on which other objects susceptible to wind are also mounted.
- Do not install the unit in locations exposed to constant vibration. Do not install the unit in a vehicle nor ship.
- Avoid installing the units on sea or shore, or in locations exposed to corrosive gas, herbicides or other sprayed liquid chemicals, or extraordinary combustible conditions.
- To prevent the unit falls off, be sure to hang the safety wire first when installing the unit.
- Outdoor-use combination cameras are designed solely for suspended installations. The dome must be suspended vertically with its dome facing downward. Use special care not to suspend it at a tilted angle.
- Do not give vibration or shock to the unit. The mounting bracket can be damaged or fallen down.
- Applicable pole diameter is 90 - 340 mm. Be sure to use 2 mounting bands. Cut the band if too long.

4. INSTALLATION

4.1. Installing the Outdoor Combination Camera C-CC714, C-CC764 or C-CC774

Be sure to refer to the instruction manual supplied with the Camera.

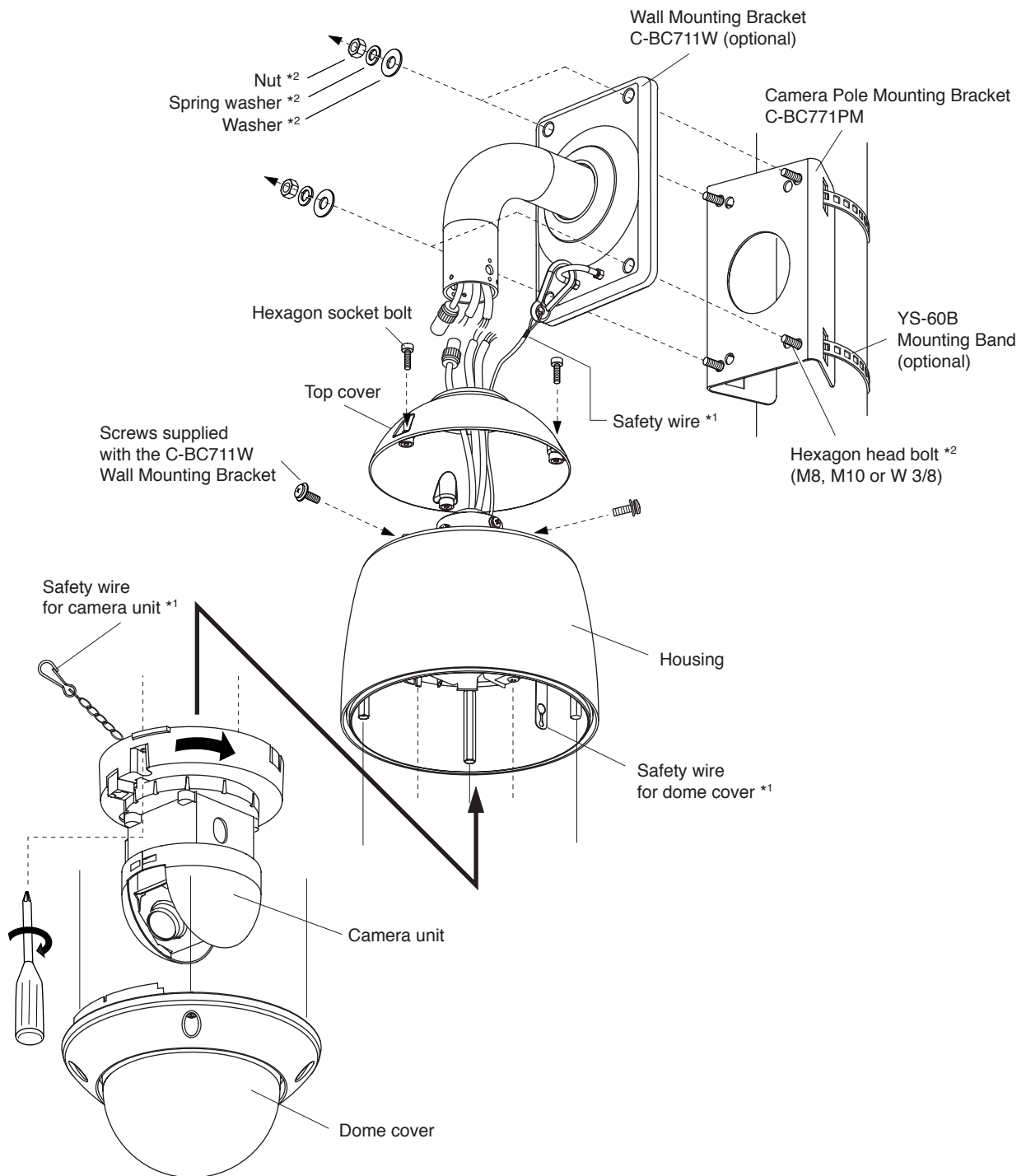

Notes

*1 Be sure to attach the Housing and the Camera after hanging the safety wire.

*2 Washers, spring washers, nuts and hexagon head bolts are not supplied and should be acquired separately.

4.2. Installing the Combination Camera C-CC704

Use the C-BC704W which has been waterproofed and through which cables have been routed. Mount the C-CC704 to the C-BC771PM with help of the C-BC704W as illustrated below.

For details, refer to the instruction manual enclosed with the C-BC704W and C-CC704.

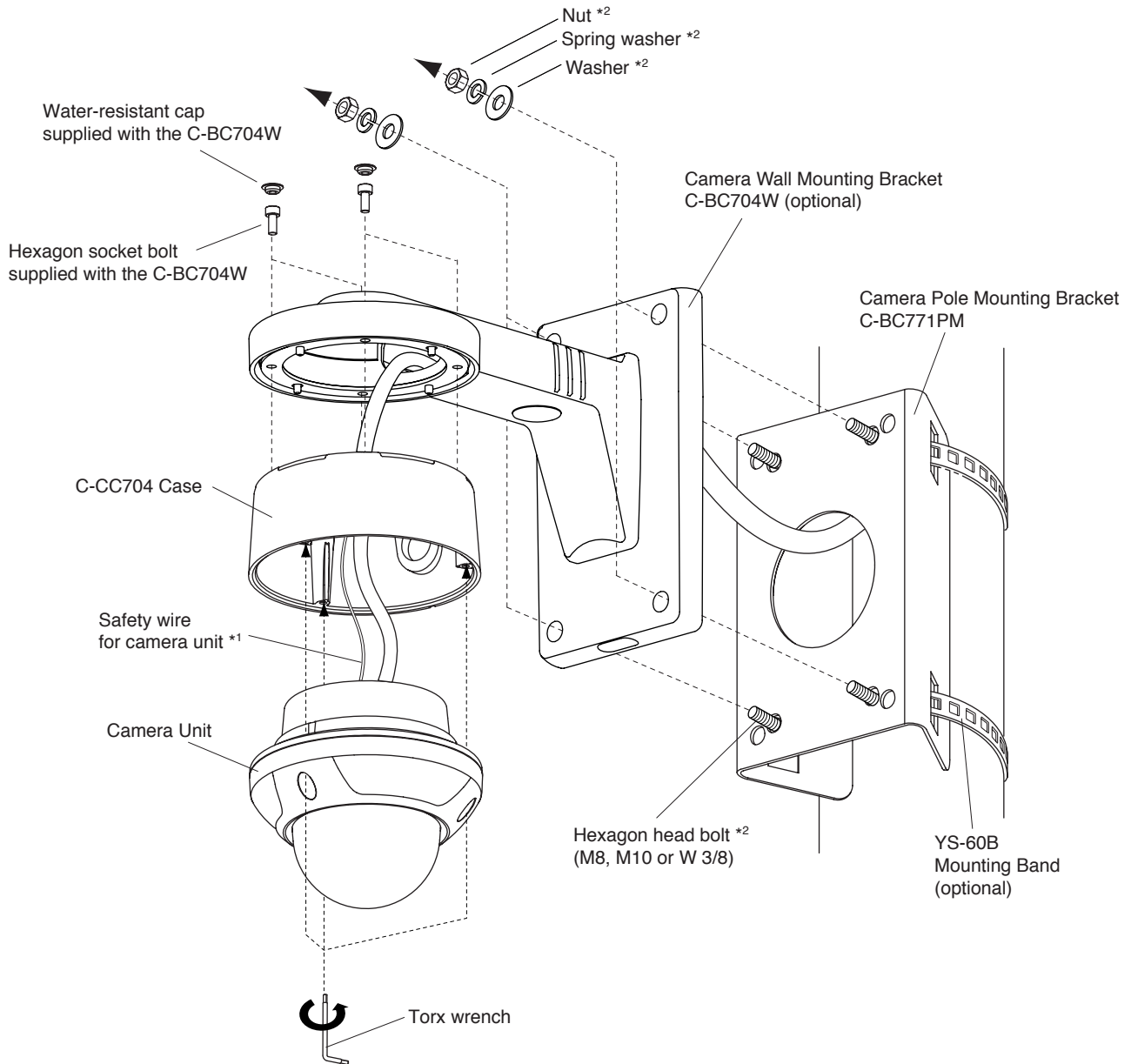

Notes

*1 Be sure to attach the Camera after hanging the safety wire.

*2 Washers, spring washers, nuts and hexagon head bolts are not supplied and should be acquired separately.

5. SPECIFICATIONS

Finish	Main body: Stainless steel
Dimensions	140 (W) x 200 (H) x 60 (D) mm (5.51" (W) x 7.87" (H) x 2.36" (D))
Weight	0.7 kg (1.54 lb)
Applicable pole diameter	ø90 – ø340 mm (ø3.54" – ø13.39")

Note: The design and specifications are subject to change without notice for improvement.