

QUICK START GUIDE

9000 SERIES AMPLIFIERS

SELECT MODE

Note: Disconnect the AC power cord before proceeding.

Choose either "MATRIX mode" or "MIXER mode" depend on your application, and select the [MODE] switch on the rear panel. (Factory preset: "MATRIX" mode)

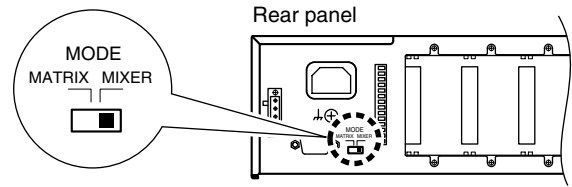

MIXER mode

This mode allows for full matrix mixing of any desired inputs to any desired outputs in the desired amounts. -- especially for background music systems, AV systems, room-combining systems, or systems using several microphones. You can also add one level of priority for basic paging functionality. The operator can make fine adjustments to the mix in real time while actually monitoring sound output. Up to 32 scene memories may be pre-set and recalled, storing all parameters including routing, EQ and volume settings. MIXER mode also provides automatic mixing (using the gate and NOM attenuation functions), selectable channel-grouping (for stereo operation), and zone-selectable priority paging with variable ducking level.

MATRIX mode

This mode is recommended for zone paging and paging with background music using muting priorities. It provides 8 levels of priority, with selection of First-In-First-Out, Last-In-First-Out or mixing for inputs sharing the same priority level. Event-based programming allows complex input-to-output assignments to be quickly changed, based on a VOX trigger or remote contact closure, without altering volume or EQ adjustments. MATRIX mode is recommended for advanced paging systems having complex dynamic routing requirements, systems using multiple priority levels, and jobs with special routing control requirements.

Continue to the following.

Refer to separate "9000 series amplifiers Quick start guide – MATRIX MODE."

1. MODULE INSTALLATION

Notes

- Be sure to install the needed modules in the proper slots before programming the unit, as changing the quantity or location of any modules will force the unit to erase all stored settings.
- Disconnect the AC power cord before proceeding.

Install modules based on the following guide.

- From right to left - Do not skip otherwise described.
- Follow the steps described below.

Step 1. Install 9000 series input modules from D-001T. ... D-001T → AN-001T

Step 2. Install 9000 series output modules. ... T-001T

Note

Output modules should be installed **from 5th slot from right.**

Step 3. Install 9000 series other audio interface modules. ... ZP-001T

Step 4. Install non-9000 series modules. ... Legacy 900 series modules

Step 5. Install non-audio modules. ... C-001T

Step 1	Audio module	9000 series modules	Inputs	D-001T → AN-001T
			Outputs	T-001T
			Others	ZP-001T
Step 4		Others	9000 series modules	
Step 5		Others	C-001T	

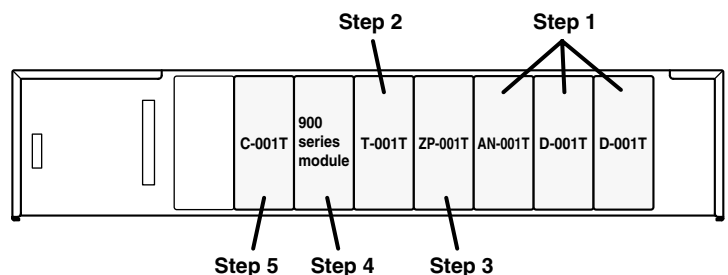

2. POWER UP

- Step 1.** Plug in the AC power cord to the AC inlet on the rear panel.
- Step 2.** Press the [ENTER] key when the request to "ERASE MIXER MEMO?" comes up on the screen. This will erase all previous programming to start fresh. The unit will complete the initialization and automatically power off.
- Step 3.** Press the [ESC/BACK] key when either message "SINGLE-OUT APPLI?" or "BGM/PAGE APPLI?" come up on the screen. Please refer to the manual on the CD-ROM for details of each operation mode.
- Step 4.** Press the [POWER] switch and proceed with programming.

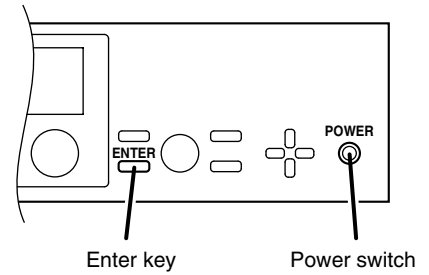

3. SETTING EXAMPLE

The following is a step-by-step to a basic configuration of a typical room combining system using A-9060DH or A-9120DH in the Mixer mode, where there are two microphones and two line level program sources from room A, and another set of two microphones and two program sources from room B. Output #1 of the amplifier is going to room A, and output #2 of it is going to room B. (Refer to the diagram)

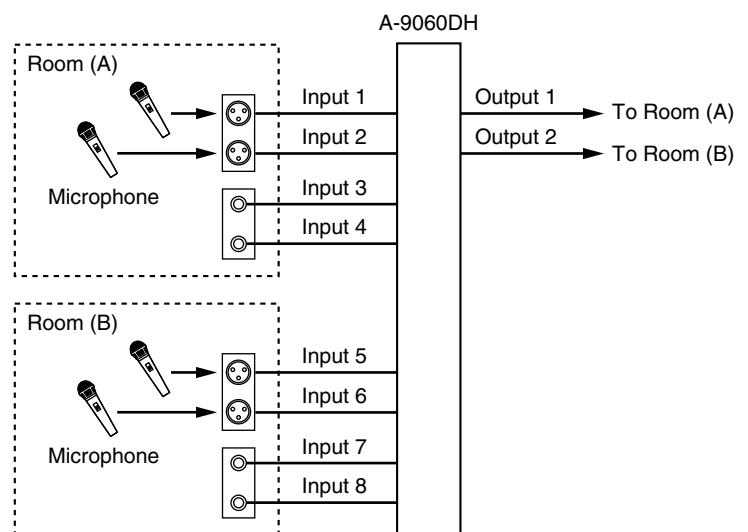

Note

Please turn down the input level of every audio source connected to each input before you power up the unit. This will avoid any excessively loud audio from speakers. Please turn those input levels up slowly after the following programming is completed.

[Input volume control]

Suggestion: -20 dB for each input level

To control level of input #1, press input #1 of [INPUT SELECT] key, and select desired level by rotating the [INPUT VOLUME] knob.

To control level of input #2, press input #2 of [INPUT SELECT] key, and select desired level by rotating the [INPUT VOLUME] knob.

Press the [MEMORY] key to have the screen go idle.

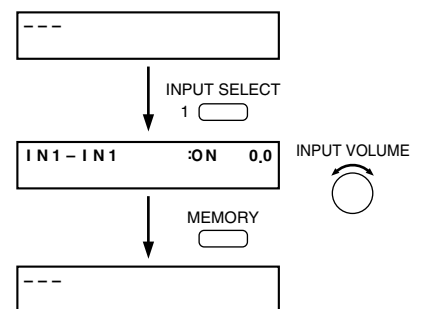

[Output volume control]

To control level of output #1, press [OUTPUT SEL] key until OUT1 will be on the display, and select desired level by rotating the [OUTPUT VOLUME] knob.

To control level of output #2, press [OUTPUT SEL] key until OUT2 will be on the display, and select desired level by rotating the [OUTPUT VOLUME] knob.

Press the [MEMORY] key to have the screen go idle.

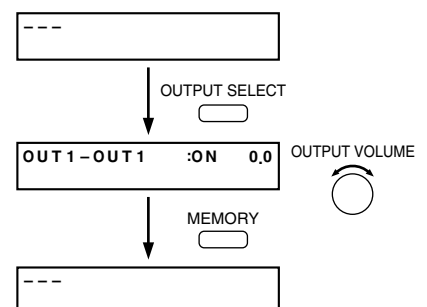

3.1. Input Setting

Step 1. Press input channel #1 with the [INPUT SELECT] key, and press [▶] key.

Step 2. Press the [▼] key to "SENSITIVITY".

Microphones should generally be set to around "-60", and line level sources to around "-10".

Note: Set sensitivity level to closest match to manufacturer's sensitivity rating for the microphone.

Rotate the [PARAMETER] knob to set the sensitivity for the input shown on the display.

Step 3. Press the [▼] key to "PHANTOM".

Choose "ON" by rotating the [PARAMETER] knob clockwise if the input channel shown on the display requires phantom power.

Note: See microphone manufacturer's specifications for phantom power requirements.

Step 4. Repeat **Step 1**, **Step 2** and **Step 3** for input channel #2, #5, and #6.

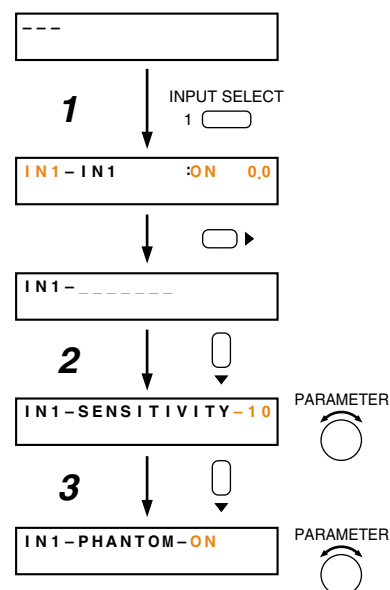

3.2. Routing Setting for "Combined Room" Application

[Store "combined room" memory]

As a factory preset, all inputs are assigned to both output #1 and output #2.

Store this routing as "combined room" SCENE memory as follows.

Step 1. Press and hold the [MEMORY] key to show "SCENE SETTING SAVE".

Step 2. Press [ENTER] key, and select the desired SCENE memory number (for example, SCENE #01) to store the parameters by rotating [PARAMETER] knob.

Step 3. Press [ENTER] key to execute. Now, "SCENE 01" is a stored memory for "combined room" application.

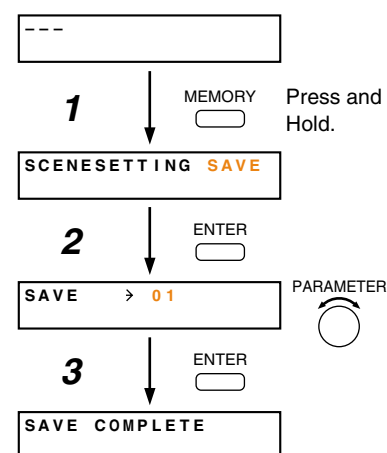

3.3. Routing Setting for "Split Room" Application

Step 1. Press input channel #1 with the [INPUT SELECT] key, and press [▶] key to show "IN1-_____".

Step 2. Press [▲] key to show "IN1 → OUT1"

Step 3. Press [▶] to show "IN1 → OUT2".

Step 4. Press "Output [ON/OFF]" keys to turn this off. You will see "-∞" on the display which means "negative infinity".

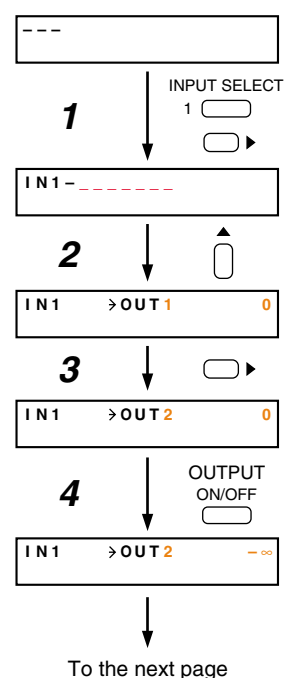

To the next page

- Step 5.** Press input channel #2 with the [INPUT SELECT] key, and repeat **Step 4**. Repeat the same procedure for input channel #3 and #4 to output #2.
- Step 6.** Press input channel #5 with the [INPUT SELECT] key, and press [◀] key to show "IN5 → OUT1".
- Step 7.** Press "Output [ON/OFF]" key to turn this off. You will see " -∞ " on the display.
- Step 8.** Press input channel #6 with the [INPUT SELECT] key, and repeat **Step 7**. Repeat the same procedure for input channel #7 and #8 to output #1.
- Step 9.** Press [ESC/BACK] key to back out of the input setting menu.

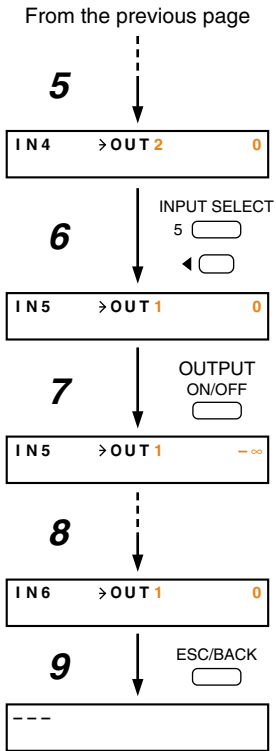

[Store "split room" memory]

- Step 1.** Press and hold the [MEMORY] key to show "SCENE SETTING SAVE".
- Step 2.** Press [ENTER] key, and select a different SCENE memory number from "combined room" memory (for example SCENE #02) to store new parameters, by rotating [PARAMETER] knob.
- Step 3.** Press [ENTER] key to execute. Now, "SCENE 02" is a stored memory for "split room" application.

After the above procedures, you will hear input channel #1 through #4 going to output channel #1 and input channel #5 through #8 going to output channel #2, which is the setting for "split room" (SCENE #02). To change to the memory for "combined room", refer to the following.

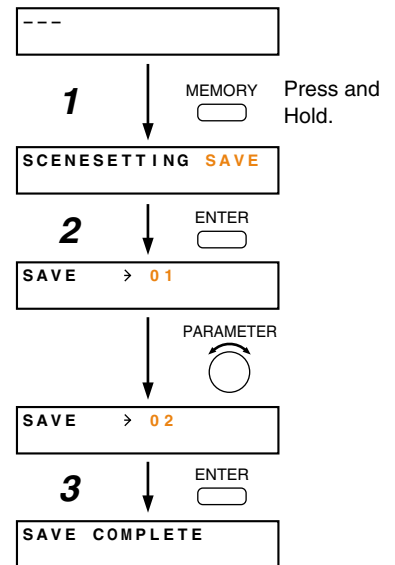

3.4. Recalling Stored Scene Memory

Press [MEMORY] key to show "LOAD" menu. Flashing number is a SCENE memory number to be loaded. Select the desired SCENE memory number (for example, SCENE #01) using the [PARAMETER] knob, and press [ENTER] key to recall it.

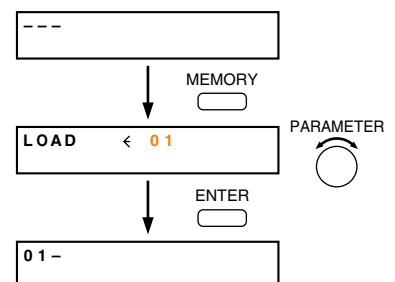

QUICK START GUIDE

9000 SERIES AMPLIFIERS

SELECT MODE

Note: Disconnect the AC power cord before proceeding.

Choose either "MATRIX mode" or "MIXER mode" depend on your application, and select the [MODE] switch on the rear panel. (Factory preset: "MATRIX" mode)

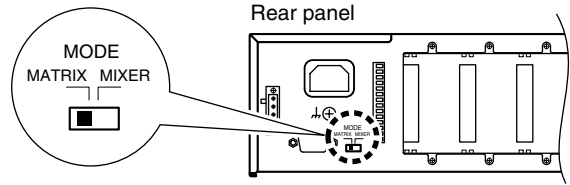

MIXER mode

This mode allows for full matrix mixing of any desired inputs to any desired outputs in the desired amounts. -- especially for background music systems, AV systems, room-combining systems, or systems using several microphones. You can also add one level of priority for basic paging functionality. The operator can make fine adjustments to the mix in real time while actually monitoring sound output. Up to 32 scene memories may be pre-set and recalled, storing all parameters including routing, EQ and volume settings. MIXER mode also provides automatic mixing (using the gate and NOM attenuation functions), selectable channel-grouping (for stereo operation), and zone-selectable priority paging with variable ducking level.

MATRIX mode

This mode is recommended for zone paging and paging with background music using muting priorities. It provides 8 levels of priority, with selection of First-In-First-Out, Last-In-First-Out or mixing for inputs sharing the same priority level. Event-based programming allows complex input-to-output assignments to be quickly changed, based on a VOX trigger or remote contact closure, without altering volume or EQ adjustments. MATRIX mode is recommended for advanced paging systems having complex dynamic routing requirements, systems using multiple priority levels, and jobs with special routing control requirements.



Refer to separate "9000 series amplifiers Quick start guide – MIXER MODE."



Continue to the following.

1. MODULE INSTALLATION

Notes

- Be sure to install the needed modules in the proper slots before programming the unit, as changing the quantity or location of any modules will force the unit to erase all stored settings.
- Disconnect the AC power cord before proceeding.

Install modules based on the following guide.

- From right to left - Do not skip otherwise described.
- Follow the steps described below.

Step 1. Install 9000 series input modules from D-001T. ... D-001T → AN-001T

Step 2. Install 9000 series output modules. ... T-001T

Note

Output modules should be installed **from 5th slot from right.**

Step 3. Install 9000 series other audio interface modules. ... ZP-001T

Step 4. Install non-9000 series modules. ... Legacy 900 series modules

Step 5. Install non-audio modules. ... C-001T

Step 1	Audio module	9000 series modules	Inputs	D-001T → AN-001T
			Outputs	T-001T
			Others	ZP-001T
Step 4		Others	9000 series modules	
Step 5		Others	C-001T	

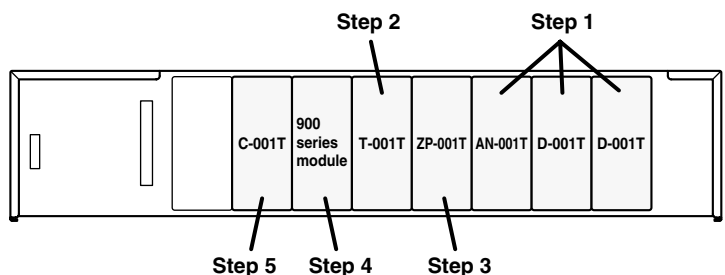

2. POWER UP

- Step 1.** Plug in the AC power cord to the AC inlet on the rear panel.
- Step 2.** Press the [ENTER] key when the request to "ERASE MIXER MEMO?" comes up on the screen. This will erase all previous programming to start fresh. The unit will complete the initialization and automatically power off.
- Step 3.** Press the [ESC/BACK] key when either message "SINGLE-OUT APPLI?" or "BGM/PAGE APPLI?" come up on the screen. Please refer to the manual on the CD-ROM for details of each operation mode.
- Step 4.** Press the [POWER] switch and proceed with programming.

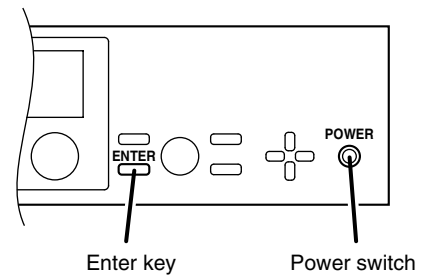

3. SETTING EXAMPLE

The following is a step-by-step guide to a basic paging configuration with a typical A-9060DH or A-9120DH system in the Matrix mode. There is a microphone in input #1, and a CD player (or equivalent line level) in input #2. The page and the BGM will share the same output #1. The paging microphone will "duck" the background music of output #1 to allow the page to go through. BGM will also go to output #2.

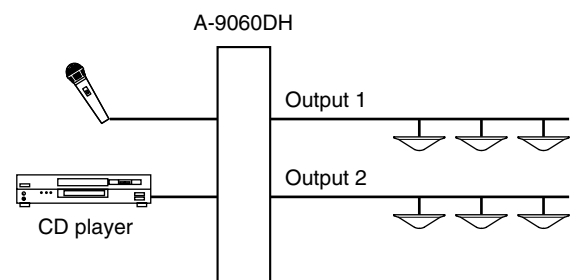

Note

Please turn down the input level of every audio source connected to each input before you power up the unit. This will avoid any excessively loud audio from speakers. Please turn those input levels up slowly after the following programming is completed.

[Input volume control]

Suggestion: -20 dB for each input level

To control level of input #1, press input #1 of [INPUT SELECT] key, and select desired level by rotating the [INPUT VOLUME] knob.

To control level of input #2, press input #2 of [INPUT SELECT] key, and select desired level by rotating the [INPUT VOLUME] knob.

Press the [MEMORY] key to have the screen go idle.

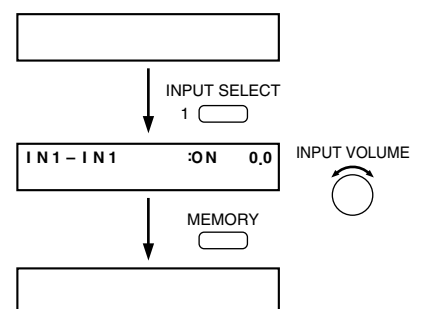

[Output volume control]

To control level of output #1, press [OUTPUT SEL] key until OUT1 will be on the display, and select desired level by rotating the [OUTPUT VOLUME] knob.

To control level of output #2, press [OUTPUT SEL] key until OUT2 will be on the display, and select desired level by rotating the [OUTPUT VOLUME] knob.

Press the [MEMORY] key to have the screen go idle.

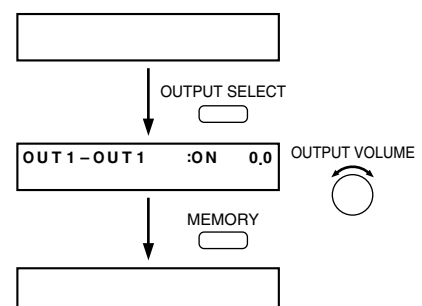

3.1. Input Setting

- Step 1.** Press and hold the [UTILITY] key until the "INPUT-SETTING" message appears.
- Step 2.** Press the [▶] key.
- Step 3.** Select input channel #1 with the [INPUT SELECT] key.
- Step 4.** Press the [▼] key to "SENSITIVITY".
Microphones should generally be set to around "-60" (**Note:** Set sensitivity level to closest match to manufacturer's sensitivity rating for the microphone.), and line level sources to around "-10".
Rotate the [PARAMETER] knob to set the level.
- Step 5.** Press the [▼] keys to "PHANTOM".
Rotate the [PARAMETER] knob to "ON" if phantom power is required.
- Note**
See microphone manufacturer's specifications for phantom power requirements.
- Step 6.** Press the [▼] keys to "VOX".
Rotate the [PARAMETER] knob to set "VOX-ON".
- Step 7.** Press the [▼] keys to "PRIORITY".
Choose "PRIORITY 1" (highest priority) by rotating the [PARAMETER] knob.
- Step 8.** Press the [▼] keys to "DUCKER".
Rotate the [PARAMETER] knob to set "DUCKER ON".
- Step 9.** Press the [ESC/BACK] key to "INPUT SETTING".

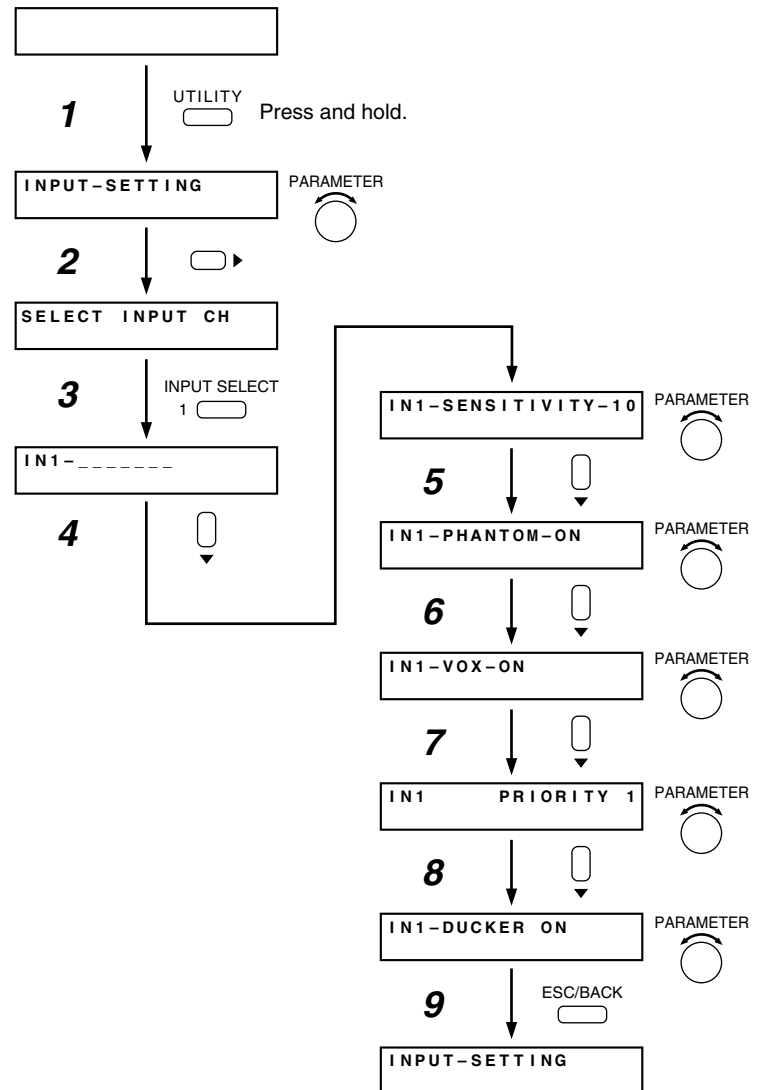

3.2. Routing Event Setting

- Step 1.** Rotate the [PARAMETER] knob to choose "EVENT-SETTING".
- Step 2.** Press the [▶] key to "EVENT01 NONE".
- Step 3.** Press the [▶] key and observe EVENT01 "NONE" flashing.
- Step 4.** Rotate the [PARAMETER] knob to choose EVENT01 "ROUTE" flashing.
- Step 5.** Press the [▼] key and observe EVENT01 "IN1" flashing.
- Step 6.** Press the #2 of [INPUT SELECT] key and observe EVENT01 "IN2" flashing.

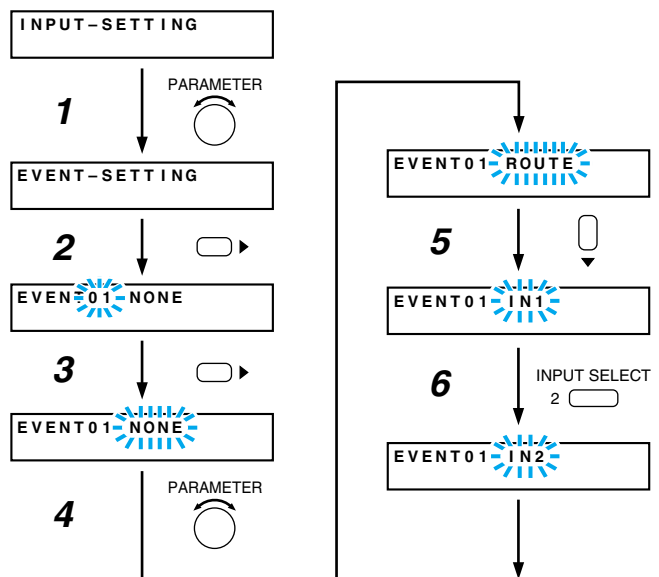

To the next page

- Step 7.** Press the [▼] key and observe EVENT01 "OUT1" flashing.
Press the "Output [ON/OFF]" key and observe a red LED next to OUT1.
Press the [Output SELECT] key and observe EVENT01 "OUT2" flashing.
Press the "Output [ON/OFF]" key and observe a red LED next to OUT1 and OUT2.
- Step 8.** Press the [▼] keys and observe EVENT01 "ROUTE" flashing.
- Step 9.** Press the [◀] key and observe EVENT "01" flashing.
- Step 10.** Rotate the [PARAMETER] knob and observe EVENT "02" NONE.
- Step 11.** Press the [▶] key and observe EVENT02 "NONE" flashing.
- Step 12.** Rotate the [PARAMETER] knob and observe EVENT02 "ROUTE".
- Step 13.** Press the [▼] key and observe EVENT02 "IN1".
- Step 14.** Press the [▼] key and observe EVENT02 "OUT1".
Press "Output [ON/OFF]" key and observe a red dot LED next to OUT1.
- Step 15.** Press the [▼] key and observe EVENT02 TRIG "NONE".
- Step 16.** Rotate the [PARAMETER] knob and observe EVENT02 TRIG "VOX".
- Step 17.** Press the [ESC/BACK] key until observe "EVENT-SETTING" flashing.
- Step 18.** Press the [MEMORY] key to save the events and the screen will go idle.

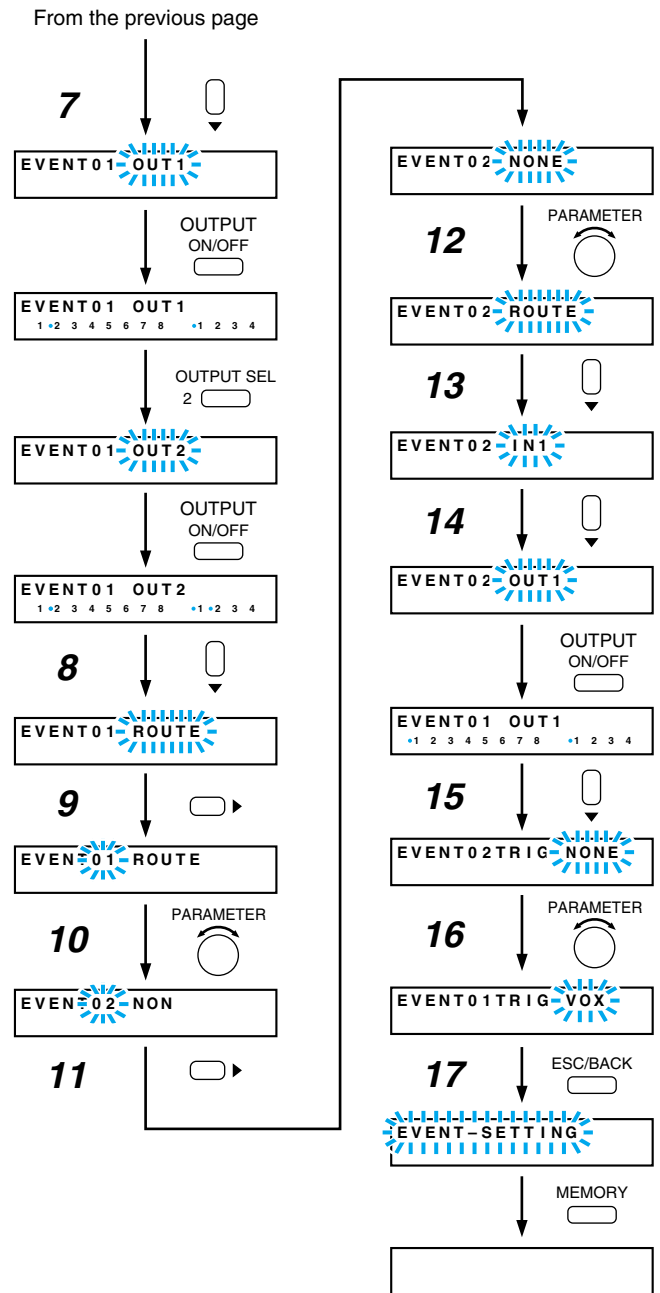

3.3. Routing Event Activation

- Step 1.** Press and hold the [MEMORY] key until observe "EVENT -->--".
- Step 2.** Rotate the [PARAMETER] knob to choose "EVENT 01 > OFF".
- Step 3.** Press the [ENTER] key observe EVENT "01 ON".
Note: You should hear BGM audio in both zones.
- Step 4.** Press the [MEMORY] key and the screen will go idle.

You will hear the BGM sound from input #2 to both output #1 and output #2 at this time.
When you talk to a microphone of input #1, BGM sound of output #1 will be muted and microphone paging sound will go to output #1. BGM of output #2 will not be interrupted.

