

# **Closed Circuit Television Systems Fundamentals Course**



**TOA Corporation**  
**TOA Electronics, Inc. (USA)**  
[www.toaelectronics.com](http://www.toaelectronics.com)  
**TOA Canada Corporation (CANADA)**  
[www.toacanada.com](http://www.toacanada.com)

## Contents

<b>1. CCTV SYSTEMS.....</b>	<b>1</b>
1-1. What are CCTV systems?.....	1
1-2. What are security systems?.....	1
1-3. How television works.....	2
1-4. Television system.....	5
<b>2. CCTV SYSTEM DESIGN.....</b>	<b>6</b>
2-1. Designing a CCTV system.....	6
2-2. Aims of a surveillance camera system.....	6
2-3. System design elements.....	7
2-4. Conditions for equipment selection.....	10
2-5. Camera installation.....	11
<b>3. CAMERA SELECTION.....</b>	<b>16</b>
3-1. Types of cameras used in CCTV systems.....	16
3-2. Power supply systems.....	17
3-3. Camera performance.....	18
3-4. Camera functions.....	20
3-5. Synchronization methods.....	23
3-6. Camera mounts.....	25
<b>4. LENS SELECTION.....</b>	<b>26</b>
4-1. Angle of view settings.....	26
4-2. Lens mount.....	27
4-3. Auto-iris lens.....	27
4-4. Types of lenses.....	28
4-5. Lens selection.....	30

<b>5.</b>	<b>MONITOR SELECTION .....</b>	<b>31</b>
5-1.	<i>Monitors .....</i>	31
5-2.	<i>Reduced image scale on monitors .....</i>	32
5-3.	<i>Notes on monitor installation .....</i>	33
<b>6.</b>	<b>SWITCHER SELECTION &amp; VIDEO RECORDING .....</b>	<b>35</b>
6-1.	<i>Sequential switcher .....</i>	35
6-2.	<i>Multi-viewer .....</i>	36
6-3.	<i>Matrix switcher .....</i>	36
6-4.	<i>Multiplexer .....</i>	37
6-5.	<i>Time-lapse VCR recordings .....</i>	39
6-6.	<i>Digital video recorders (DVR's) .....</i>	40
<b>7.</b>	<b>SENSOR TYPE SELECTION .....</b>	<b>41</b>
7-1.	<i>Infrared sensors .....</i>	41
7-2.	<i>Passive sensors .....</i>	43
7-3.	<i>Motion detectors .....</i>	43
<b>8.</b>	<b>REMOTE-CONTROLLED SURVEILLANCE AND NETWORK CAMERAS .....</b>	<b>44</b>
8-1.	<i>Remote-controlled surveillance .....</i>	44
8-2.	<i>Network camera system .....</i>	45
<b>9.</b>	<b>VIDEO SIGNAL AND CONTROL SIGNAL TRANSMISSION .....</b>	<b>47</b>
9-1.	<i>Coaxial cables .....</i>	47
9-2.	<i>Twisted-pair cable transmission .....</i>	48
9-3.	<i>Control signal circuits .....</i>	48
9-4.	<i>Electrical power construction requirements .....</i>	51
<b>10.</b>	<b>Making Drawings .....</b>	<b>52</b>
10-1.	<i>Preparing block diagrams .....</i>	52

10-2. CCTV drawing symbols.....53

*Appendix Unit Conversion Table*

# 1. CCTV Systems

## 1-1. What are CCTV systems?

Television systems are now one of the most indispensable information and communications means in our daily life. They can be broadly classified as shown in Figure 1-1, and are used in a wide range of applications, including standard television broadcasts.

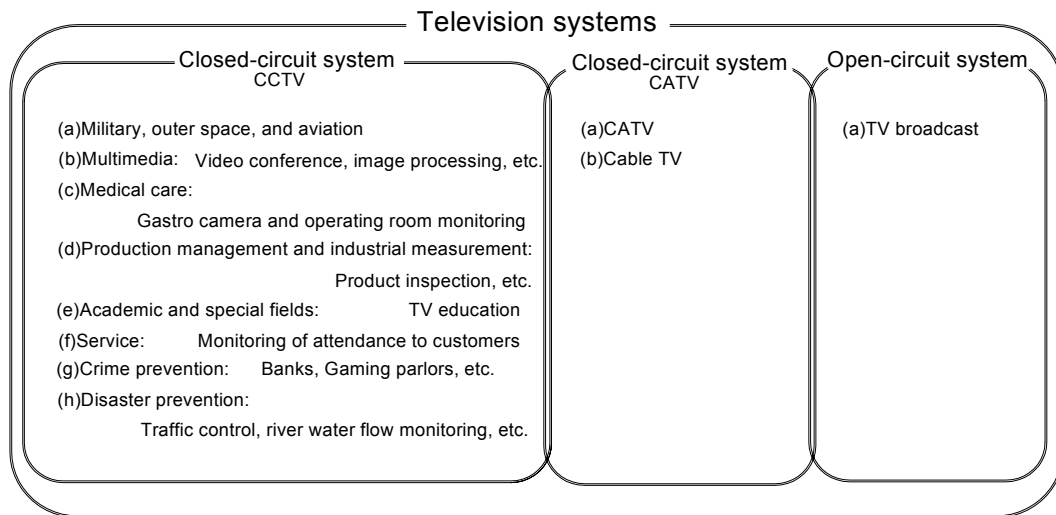

Figure 1-1. Television Systems

An open-circuit system refers to a system that is targeted at an indefinite number of people, as in television broadcasts. Closed-circuit systems, on the other hand, are designed to provide video to specified viewers. One closed-circuit system that is primarily designed for surveillance purposes is generally called a closed-circuit television or CCTV system. CCTV is used in a wide variety of applications which include security, disaster prevention, energy and manpower saving, sales promotion and information services, production management, industrial measurement, medical care, education and military fields.

## 1-2. What are security systems?

Security systems are integrated systems made up of different types of equipment and devices, the combined operation of which helps protect human lives, property, the environment and information. Crime prevention literally represents preventing violation of the law and public interests and disturbances to social order through acts of crime, which should be punished by law. Crime prevention facilities and equipment are classified as shown in Figure 1-2. Long-distance picture transmission systems and surveillance camera systems are encompassed within CCTV systems designed for crime prevention.

The aims of the installation of crime prevention facilities are to let criminals know the risks of crime and function as a deterrent of crime or keep constant watch over potential criminal acts. When a criminal act is detected, the facility's sensors or emergency warning

switches are operated to sound an alarm and ideally cause criminals to go elsewhere. Thereafter, information is sent to related departments or personnel for taking appropriate measures to avoid loss.

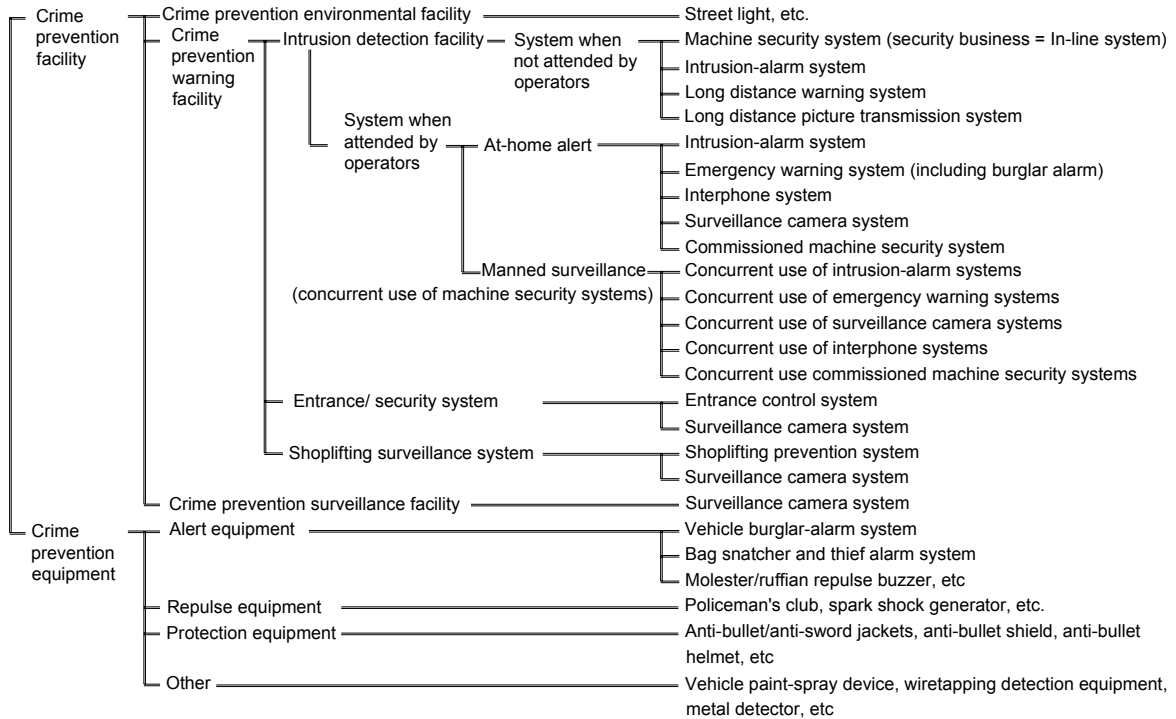

Figure 1-2. Classification of Crime Prevention Facilities and Equipment

### 1-3. How television works

A camera is analogous to the human eye and light passing through its lens is changed into an electric signal by means of a charge-coupled device (CCD) or other image sensors that correspond to the eye's retina. The electric signal is output to a monitor via electrical circuitry.

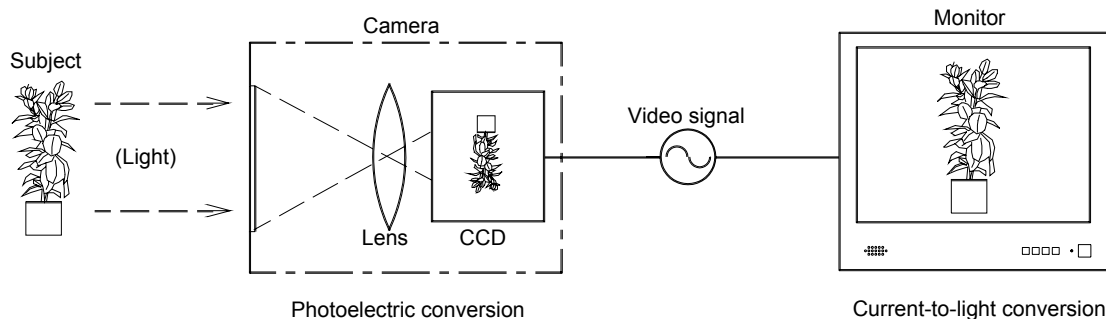

Figure 1-3. The principle of Television Operation

The monitor's image is made up of small black and white or Red, Green and Blue dots (or pixels) similar to those that can be seen when a newspaper photo is enlarged. Like these small printed dots, the smallest element the monitor uses to configure an image is called a pixel. In newspaper photos, the size of the dot varies to create light and shade, but in television, the size of each dot remains the same, with shades of lighter and darker dots arranged accordingly. The greater the number of image pixels, the more finely on-screen details can be clearly seen and a high-resolution image can thus be obtained.

Table 1-1. The number of pixels in the video medium

Medium	Number of pixels
8mm video	Approximately 50,000 pixels
16mm video	200,000 pixels
35mm video	1,000,000 pixels
Television (NTSC system)	300,000 pixels
Television (PAL system)	300,000 pixels
High-definition television (720P)	1,000,000 pixels

In a television system, pixel energy is converted into electric energy and transferred to another location, where the converted electrical energy is further converted into light. This process of converting light into electrical energy is referred to as "photoelectric conversion," while the reverse is referred to as "current to light transference." It follows that cameras are photoelectric conversion devices and monitors or televisions are current-to-light transference devices.

Regarding methods of conveyance, each pixel's black and white brightness and darkness or color tone is converted into electrical signals in an orderly sequence, similar to repeatedly reading text from left to right till the end of the page is reached.

The converted electrical signal is then transmitted to a television monitor which in turn arranges each pixel in the same order and same positional relation and at the same time reproduces each pixel's black and white darkness as well as color tone from the electrical signal to reconstruct the same image as the original. In other words, the image to be transmitted is resolved in specified order and the pixels of the resolved image are reconstructed in the same order. This operation is called scanning and the operation of enabling solution scanning at the camera in step with scanning reconstruction at the monitor is called synchronization, while matching the timing, as just stated, is called synchronizing.

Because the human eye experiences an afterimage phenomenon, if one picture is transmitted every 1/30-second (NTSC) or 1/25-second (PAL), the human eye perceives it as a moving image. This single picture is referred to as a frame and its scanning method is as noted above. In reality, however, the beam first scans lines 1, 3, 5 and when it reaches

the bottom of the picture area, a rapid retrace takes place. The beam then scans lines 2, 4, 6 until it reaches the bottom then repeats. Using this method, when transmitting 30 (NTSC) or 25 (PAL) screen frames per second, it appears that two-times coarse 60 (NTSC) or 50 (PAL) field screens are transmitted. Therefore, 2 fields equal 1 picture frame image.

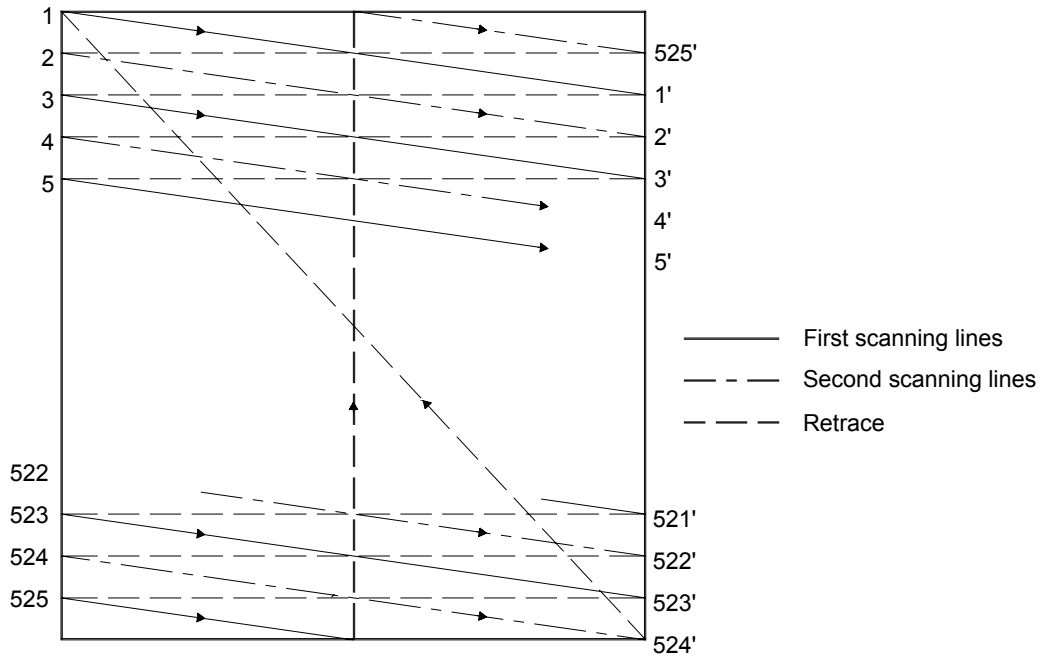

Figure 1-4. 2:1 Interlace (NTSC system)

This method is called “scanning line interlace”, in which the method of scanning exactly the center of the space between two previous lines is called a 2:1 interlace and that of scanning an arbitrary path between two previous lines is called random interlace. The 2:1 interlace is generally used in surveillance camera systems. The random interlace produces screen flicker or deterioration of vertical resolution, but because of its simple circuit construction, it is sometimes used in small surveillance camera systems.

With the recent movement from analog to digital technologies, some televisions employ the progressive scanning system, which features higher resolution and is used when reproducing pictures. In NTSC television, for instance, the progressive scanning system scans all 525 lines in succession, instead of scanning odd-numbered and even-numbered lines alternately like the interlace method, thus reducing flicker.

#### 1-4. Television system

Unless the element that determines the television system is standardized, the compatibility between components that sense an image, transmit the signal and receive it cannot be achieved. Each of the NTSC, PAL and SECAM systems is one of the world's largest television systems. The NTSC system is employed in such countries as the United States, Canada, Japan, Korea and Taiwan. The countries that use the PAL system include western European countries, China, Asian countries and Middle Eastern countries. The SECAM system is employed in France, Russia and other eastern European countries, African countries and parts of the Middle East.

Table 1-2. Standard of the World's Three Largest Television Systems

	NTSC	PAL	SECAM
No. of scanning lines	525 lines	625 lines	625 lines
No. frames	30 frames/sec	25 frames/sec	25 frames/sec
Field frequency	60Hz	50Hz	50Hz
Interlaced scanning	2:1	2:1	2:1
Vertical-to-Horizontal ratio	3:4	3:4	3:4
Video frequency band	4.2MHz	5.5MHz	5.5MHz
Video frequency band	6MHz	7MHz	8MHz

Further, the following video signal methods exist:

##### 1) Composite video signal

Called VBS (Video and Color Burst signal) for color and VS (Video and Sync) for monochrome, these signal method(s) are currently used for most video signals. It consists of a luminance signal (Y), color signal (C), horizontal/vertical synchronizing signal (S) and color synchronizing signal (B). However, the color signal and color-synchronizing signal are not used for monochrome.

##### 2) Y/C signal

This method transmits a luminance (Y) signal and a color (C) signal separately for higher resolution.

##### 3) RGB signal

In this signal, which is used in many industrial-use video projectors, the red (R) signal, green (G) signal, blue (B) signal, horizontal synchronizing signal (H) and vertical synchronizing signal (V) are separated. Although a personal computer's monitor output employs this method, since the video frequency band differs depending on the type of equipment, care is needed in setup.

## **2. CCTV System Design**

### **2-1. Designing a CCTV system**

System design may sound difficult, but what is important is “The aim of the system,” that is, “What a building owner requires of the system.” Making this aim concrete is the system design. Dividing work into the following procedures will facilitate the system design.

- 1) Understand the intended aim of the system.
- 2) Study the installation locations of cameras and monitors.
- 3) Understand the environments where cameras and monitors will be installed.
- 4) Select cameras, lenses, and pan/tilt drives.
- 5) Select signal routing, monitors, and switchers.
- 6) Select recording methods.

Let’s proceed with the design by following these procedures.

### **2-2. Aims of a surveillance camera system**

The aim of the CCTV system is broadly classified into the following categories:

#### **1) Security (Crime Prevention)**

This application is generally referred to as “crime prevention cameras”. This aims not only to create a psychological effect to act as a deterrent to crime, such as theft and molestation, but also to help identify criminals after crimes are perpetrated by reviewing recorded images resulting from the installation of a CCTV system. The system is used to monitor conditions of facilities and places where people, material goods and money converge.

#### **2) Safety (Disaster Prevention)**

The CCTV system is also installed in facilities and places where accidents and disasters are liable to occur. Its main aims include the prevention of accidents caused by natural or man-made disasters, minimization of property loss and personal injury resulting from disasters. This permits understanding the situation immediately after the occurrence of accidents or disasters and examination of the cause of accidents after they occur.

#### **3) Manpower Savings**

The aim is to reduce manpower, expenses and time. The number of active security guards can also be reduced in the above security and safety applications.

#### **4) Customer Service**

The CCTV system is used to improve service to customers. Examples of this include: store owners monitoring and improving employees’ attitudes toward their customers, skiers

at ski resorts checking the congestion of the slope on the monitor installed in their hotels, and waiters monitoring the timing for the delivery of the next course in a restaurant.

## **5) Other Applications**

Other aims include applications such as: video conferencing, sale presentations and distance learning educational television systems.

### **2-3. System design elements**

Based on the system's intended purpose, examine the number of cameras, monitors and their installation locations. System design should usually begin with clarification of the input and output of an image and/or sound. In other words, the "Input device" implies cameras and microphones, while "Output device" refers to monitors and speakers. Determining these elements first, followed by components connected to such equipment, will permit the system to be easily designed.

The range of areas or rooms to be monitored can to a certain extent be imagined without actually visiting them, depending on the types of buildings or facilities the system is installed in. Let us give you some concrete examples.

#### **1) Convenience Stores**

With the increase in the number of convenience stores where ATM's and color copy machines are installed, the number of crimes at these facilities has also increased. It is said that convenience stores suffer much damage and loss resulting from shoplifting and employee theft. This is a situation that has stimulated demand for surveillance camera systems. The standard convenience store system consists of four fixed cameras, with dummy (nonfunctional) cameras added in many cases if four cameras are insufficient.

The range of areas to be monitored: Inside the store and particularly blind spots hidden from the sales counter.

Subjects: Products, suspicious customers and clerks' attitudes toward customers.

Monitoring room: Office or home.

Monitoring person: Store manager or owner (who usually does not like a complicated system operation).

#### **2) Financial Institutions**

The system not only acts as a deterrent to robbery, but also assists in police investigations by providing the police with video evidence. The number of cameras to be installed in financial institutions largely differs depending on their size.

The range of area to be monitored: Places where cash is handled, teller windows, safes, ATM areas, customer checkout line and back doors.

Subject: Robberies and suspicious customers, especially their faces.

Monitoring room: Office and security guard room.

Monitoring person: Clerks and security guards.

### **3) Office Buildings**

A great number of surveillance camera systems have been installed in public facilities and large buildings in order to maintain safety by quickly detecting crime and taking appropriate actions.

The range of area to be monitored: Building entrances, emergency exits, public spaces and rest room entrances.

Subject: Suspicious object left unattended and suspicious persons.

Monitoring room: Office and security guard room.

Monitoring person: Security guards.

### **4) Senior Citizen Centers and related facilities**

With the rapid increase in the number of elder care facilities relative to the quick pace of aging society, care facilities intended to accommodate Alzheimer's and other patients have also increased in number. Many facilities suffer shortages of workers to take care of these elderly people. To compensate for this manpower shortage, some facilities have employed surveillance camera systems to maintain the safety of those living and working in these facilities. However, since many of these elderly people are long-term care patients, special considerations must be given to the camera installation method in order to protect their privacy. Because patients suffering senile dementia often loiter around outdoors without any particular purpose, they need to be monitored by surveillance systems in which cameras are interlocked with sensors specially installed at building entrances and windows in order to prevent accidents.

The range of area to be monitored: Corridor, lobby, entrance, visiting room and garden.

Subject: Facility occupants and suspicious persons.

Monitoring room: Office, security guard room and night watchman's room.

Monitoring person: Nursing Staff and security guards.

### **5) Hospitals and Other Medical Facilities**

Places to monitor include the lobby, waiting room and entrance. Taking into consideration the fact that some visitors dislike overt cameras, perform unobtrusive monitoring by using dome type cameras.

### **6) Department Stores and Supermarkets**

The surveillance camera system is installed as a means to prevent and detect shoplifting as well as fraudulent insurance claims from staged accidents. Not only does the system monitor the inside of the store, but it also acts as a deterrent to shoplifting by overtly

showing cameras to indicate that shoplifters are being watched. It permits all camera images of the inside of the store to be monitored from the office, thereby leading to smooth customer flow and improvement of service. For example, by monitoring checkout or sales areas, the number of checkout or sales clerks can be increased or reduced depending on the checkout processing time.

It is also possible to monitor sales areas or parking lots from the security guard room. By installing a surveillance camera system, security guard workloads are reduced, leading to possible staff cutbacks, which can in turn eventually reduce expenses.

## **7) Hotels**

Installing the system at the entrance, hall, lobby, elevator or parking lot can help prevent troubles with guests. Dome-type covert cameras are used in hotels as well. One application is to install cameras in the banquet hall to monitor from the kitchen to check the timing for serving meal courses. In wedding ceremonies, high-quality 3-CCD cameras are used to relay video images of the ceremony to the outside or record them on a videocassette or DVD system.

## **8) Factories**

Specially designed industrial-use camera systems are used for product inspection, but normal camera systems are used to monitor work progress. The aims of these systems are to analyze work processes for higher productivity or to monitor dangerous locations to document accidents. In particular, surveillance cameras are installed in clean rooms or other locations that workers cannot easily access, so that the work operating conditions or instruments are monitored. Since specially designed camera housings may be required in factories for protection of the camera against dust, heat or chemicals, care is needed when designing the factory systems.

## **9) Transportation**

At train stations, surveillance systems are installed to monitor arriving and departing trains in order to prevent accidents on the platform. The systems are also used for transmitting information or providing guidance. For example, passengers in a station can view monitors displaying the train arrival and departure information as transmitted from the camera.

## **10) Other Applications**

Many other applications and aims of camera surveillance include monitoring of dams (for prevention of accidents when water is discharged) and traffic congestion.

The range of areas to be monitored should be carefully determined in consultation with owners and architects, with the cameras installed in the locations finally selected.

#### 2-4. Conditions for equipment selection

As noted above, the CCTV system is basically comprised of the camera, monitor and signal transmission path that connects the two. When selecting the camera, it is important to consider performance that is appropriate for the intended application. Regarding camera housings, it is important to select the most appropriate type depending on where each camera is to be installed. Pan/tilt heads and lenses may also be required depending on the mounting method or the monitoring range. In addition, accessories and remote controllers for operating the camera movement from distant locations may be required. Table 2-1 shows conditions that must be determined for equipment selection.

Table 2-1. Conditions for Equipment Selection

Conditions to be Determined	Contents to be examined	Equipment to be selected
Subject or place	Color and brightness	Color/monochrome camera and high-sensitivity camera
Target and observation range	Size of target and room	Lens(wide-angle, standard and zoom),number of cameras and motorized pan/tilt head
Camera's external View	Shape of camera and installation method	Dome camera, pinhole lens, etc.
Installation place	Temperature, humidity, dust and rain	Camera housing and outdoor box
Mounting method	Wall, ceiling, and pole	Mounting hardware
Synchronization Method	System configuration unit power frequency (50 or 60Hz) and wiring method	Vertical gen-lock and drive unit
Distance to camera	Maximum cable length and frequency bandwidth	Cable compensator, relay box, media converter, transmitting device and LAN equipment
Monitor screen size	Size of monitor room and aim of surveillance	Monitor: CRT or LCD typically
Monitor display Method	Number of cameras, sequential display and multi-segment split-screen display	Switcher, Multi-viewer and multiplexer
Number of monitors	Number of cameras, size of monitor room, number of places monitored and aim of surveillance	Video signal splitter, switcher, Multi-viewer, multiplexer and Matrix switcher
Video recording System	Aim of recording, media and time interval	Time-lapse VCR, digital video recorder and video printer
Instant response Capability	Aim of surveillance	Sensor and preset memory system
Equipment storage	Storage form	Monitor rack, cabinet rack and mounting hardware

## 2-5. Camera installation

### 1) Notes on camera installation positions and orientation.

This section describes precautions designers should bear in mind when installing cameras in one area.

(a) An ultra-wide angle lens is required regardless of the room size when monitoring a whole room.

(b) The use of an ultra-wide lens makes a subject smaller.

(c) Two or more cameras are required to display a subject in a close-up and monitor a whole room.

(d) If space does not permit multiple cameras to be installed, use pan/tilt heads or zoom lenses.

(e) Avoid backlight conditions. (Be aware of windows facing east or west.) When necessary, use cameras that provide backlight compensation such as the TOA Wide Dynamic Range cameras.

(f) When planning a small system, a camera and monitor can be used to select the optimal location for camera placement. There are methods of simulating the picture range to be displayed on the monitor using a PC and the appropriate software such as the TOA CMS software.

### 2) Installation environments

Following the determination of the camera installation location, take care to completely understand the environment where the cameras are to be installed, then specifically select the necessary equipment. First, select the camera, lens, housing, and motorized pan/tilt head. Conditions that you should know are as shown in Table 2-2.

Table 2-2. Installation Environment Conditions that must be understood

Condition for Selection	Examination Item
Brightness	Cameras minimum subject illumination
Backlight phenomenon	Cameras backlight compensation
Temperature, rain, dust and explosive atmosphere	Camera housing function
Lightning and electromagnetic wave	Cameras video output
Privacy	Camera shape, installation method and image blocking capability

### 3) Brightness

The camera to be used also needs to be considered depending on the brightness of the subject to be monitored. Monochrome cameras require brightness of at least 100 lux, while color cameras require that of over 300 lux in terms of recommended subject illumination.

When wishing to monitor subjects in low light conditions, consider turning on lights or using high-sensitivity or infrared ray cameras. To maintain visibility in smoky conditions, thermal cameras other than the infrared ray cameras can also be used.

(a) High-sensitivity Camera

This camera achieves high sensitivity with minimum subject illumination (0.03lx) by slowing down shutter speed and using signal accumulation. One drawback of this camera is that the signal accumulation method causes a frame-by-frame image advance or lingering afterimage.

(b) Infrared Camera

This camera uses a CCD sensitive to light in the near-infrared region of the spectrum. In surveillance applications, it may be used in conjunction with a near-infrared emitter to enable nighttime surveillance even in pitch darkness. Note, however, that the video images thus produced are monochrome and the range of observation may be limited depending on the near infrared emitter capabilities.

(c) Thermal Camera

This camera uses a CCD sensitive to light in the far-infrared region of the spectrum. It was originally developed for monitoring temperature distribution in medical and research applications. In the past this type of camera was typically expensive and somewhat difficult to handle, particularly due to its cooling components, newer versions that are easier to handle and more economical have lately become commercially available.

#### 4) Temperature and Humidity

(a) Temperature

The operating temperature range for cameras in general is 14°F to 122°F(-10°C to 50°C). A protective housing will be required for any camera installed in a place where temperatures outside this range are anticipated. Two types of housing are available, one being a simple housing only, the other housing outfitted with temperature-adjustment devices like heaters and/or fans.

Cameras can be equipped to endure even higher temperatures if necessary, by outfitting them with housings incorporating electronic coolers (for ambient temperatures up to 150°F or 70°C) or water coolers (for ambient temperatures up to 212°F or 100°C).



Fig. 2-1 Camera Housing

(b) Humidity

The most hazardous condition affecting camera operation is the formation of dew resulting from rapid increases in relative humidity. Such dew condensation occurs when moisture in the air condenses into water droplets on a solid surface. If this takes place inside the camera or lens, it can cause the metallic parts to rust or corrode, eventually leading to malfunction or early failure of the camera. Consequently, it is necessary to house cameras within a sealed case.

**5) Lightning**

If a camera or its wiring is installed outdoors in a region frequently subject to lightning strikes, steps must be taken to protect the equipment from lightning damage. Protection from direct lightning strikes generally requires large-scale measures like lightning rods, without which it is difficult to counter the risk of damage. However, it is possible to protect the equipment from the lesser hazard of lightning striking the ground in the vicinity by installing a video signal protector. A CCTV system generally requires three different types of protectors, one each to protect the video signal, power supply, and control signal.

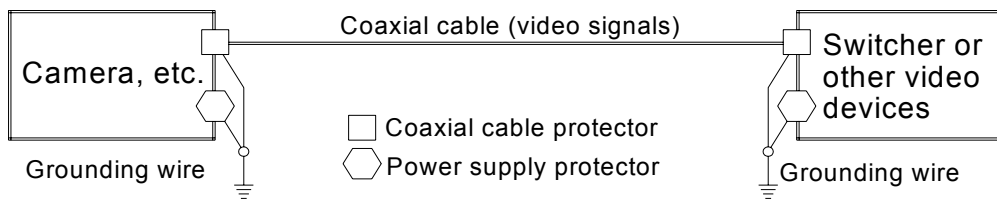

(a) Protector installation locations



(b) Coaxial cable protector

Fig. 2-2 Protectors

**6) Electromagnetic Waves**

If cameras are installed under high-voltage power lines or in the vicinity of a broadcasting station, noise may appear on the monitor due to induction. The high frequencies, such as video signals, make it very difficult to eliminate such noise entirely, but some improvement may be gained by using a video transformer. With coaxial-cable superimposition (sin-

gle-cable) type cameras, however, such a transformer must be of the DC passing type to allow installation. Another convenient counter-measure is to equip the camera with a grounding wire.

## **7) Radiation**

Because most of the CCD elements used in cameras are vulnerable to radiation, cameras installed in nuclear power plants are usually based on image-pickup tubes or incorporate special radiation-resistant CCD's. In medical radiology labs, CCD cameras can be used because the intensity of the radiation is lower than in nuclear power plants, but they are still affected over time and must be replaced at regular intervals. In x-ray photography rooms and cobalt treatment rooms, the surface of the camera lens typically discolors brown over time, blurring the video image, and the camera image itself is affected by white spots that eventually expand to fill the whole screen. Therefore, such cameras are usually installed within a protective housing, the front glass of which is regarded as a consumable part to be replaced as needed.

## **8) Corrosion**

Protecting cameras against corrosive environments is very difficult. The required measures, such as coating or sealed construction, can be very expensive. If surveillance is required in corrosive environments, the only possible protective measure is to minimize corrosion by choosing the best (minimum exposure) installation placement. In locations near the seashore, salt-carrying sea breezes are likely to corrode metallic parts. In swimming pool facilities the culprit is likely to be chlorine vapor rising from the pool water. Cameras are also vulnerable to corrosive gases including ammonia, hydrochloric acid, sulfur dioxide, hydrogen sulfide, chlorine, fluorine and carbon disulfide. Particular care may be required in factories handling or processing paper pulp, fertilizers, non-ferrous metals, soda, sulfuric acid and synthetic fibers.

## **9) Explosion-Proof Areas**

In operations like petrochemical plants and tunnel-excavation sites where flammable liquids are handled or there is a strong danger of flammable gas leakage, strict regulations are applied to all installed equipment and electrical works. When installing surveillance camera systems in such places, it is absolutely necessary to select camera models with appropriate specifications meeting local legal and regulatory requirements, for example those with explosion-proof housings.

## **10) Rain and Dust**

The rainproof outdoor housings are used wherever cameras might be exposed to precipitation such as: where water sprinklers are used for cleaning, or where considerable

exposure to water droplets is likely (e.g. swimming pools). Similarly, dustproof indoor housings are used in dusty indoor locations, not only for the camera, but also to protect relay boxes and other peripheral equipment.

Depending on ambient temperature and humidity, the front glass panel of the camera casing can become clouded by condensation or frost. Defrosters are available to handle such conditions. Similarly, wipers may be used for surveillance in the rain. Both defrosters and wipers may be turned on and off by the remote controller as needed.

Camera housings manufactured in compliance with IEC (International Electro technical Commission) standards bear “IP” grades used mainly to rate types of boxes. Table 2-3 below describes IEC529 Protection Grades.

Table 2-3 IEC 529 Protection Grades

IP–OΔ O: First characteristic : Protection against interference by the human body and foreign objects

Δ: Second characteristic — Protection against water entry

First Characteristic	Contents
0	No protection provided.
1	Fingers cannot touch charged internal components. (Diameter: 50mm)
2	Fingertips cannot touch charged internal components. (Diameter: 12mm)
3	Solid objects like tools and wires exceeding 2.5mm in diameter or thickness cannot enter the unit.
4	Solid objects like tools and wires exceeding 1.0mm in diameter or thickness cannot enter the unit.
5	Designed to prevent the entry of dust particles (to a degree that operation is not adversely affected).
6	Dust particles do not enter the unit (to a degree that seals the unit completely against dust particles).

Second Characteristic	Contents
0	No protection provided.
1	Not adversely affected by vertically descending water drops.
2	Not adversely affected by water drops arriving at angles less than 15° to the perpendicular.
3	Not adversely affected by rain that falling at angles less than 60° to the perpendicular.
4	Not adversely affected by water splashing from any direction.
5	Not adversely affected by direct water streams or jets from any direction.
6	Not adversely affected by strong, direct water streams or jets from any direction.
7	Water does not enter the unit even when it is completely submerged in water to a specified pressure for a specified period of time.
8	Can be used constantly while submerged in water.

### 3. Camera Selection

#### 3-1. Types of cameras used in CCTV systems

##### 1) Color and Monochrome Cameras

Color cameras can send images in color to the monitor screen. They are relatively more expensive than monochrome cameras, but recently have come to be used in most CCTV applications.

For surveillance applications in particular, it may be important to be able to recognize clothing or vehicle color. Some color cameras come with an increased sensitivity function that use image accumulation to deliver images of subjects in conditions with low illumination.

Monochrome cameras (also called “B&W” or black-and-white” cameras) are less expensive than color cameras. Generally they have lower minimum illumination requirements compared to color cameras and therefore can produce clearer images of dark objects. They also usually use single-plate type CCD’s, meaning they can produce images with higher resolution than color cameras.

##### 2) Camera Shapes

CCTV cameras are available in various shapes including cylindrical, box, dome and combination dome types, each appropriate for specific applications and purposes.

###### (a) Cylindrical and Box Types

Either a cylindrical or a rectangular outer form can be selected depending on the size and design of the installation space.

###### (b) Dome Type

The camera is covered with a dome that conceals it from casual view. Both the horizontal (pan) and vertical (tilt) orientation of the camera can be adjusted. Most models come equipped with a built-in 2X manual zoom lens.

###### (c) Combination Dome Types

Camera, motorized pan/tilt head and motorized zoom lens are integrated into a single unit, operated by using a remote control. The camera case is sealed to provide excellent protection against dust and moisture and helps to reduce noise (including the noise generated by camera rotation).



Fig. 3-1 Camera Shapes

### 3-2. Power supply systems

#### 1) AC-Mains System

Power is supplied to the camera via the AC mains. Since the AC mains is also used to power many other pieces of equipment besides the camera, it may be a lower-cost option (depending on the conditions).

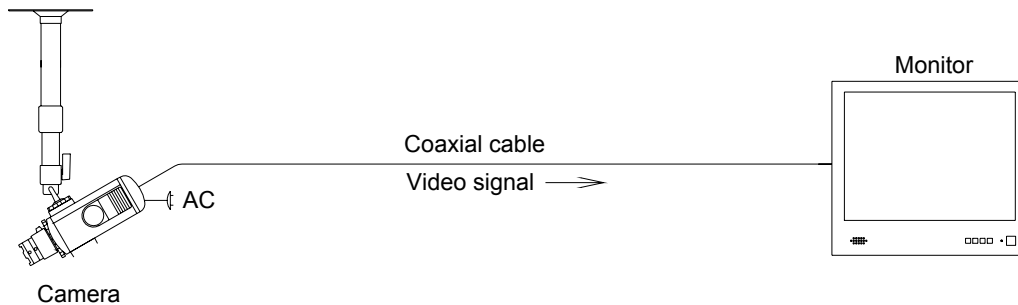

Fig. 3-2 AC-Mains System

#### 2) 24V AC System

Power is supplied to the camera via a 24V AC power supply, typically a 24V adapter or a relay box. This system reduces the total cost when the camera is used in combination with a housing and pan/tilt head.

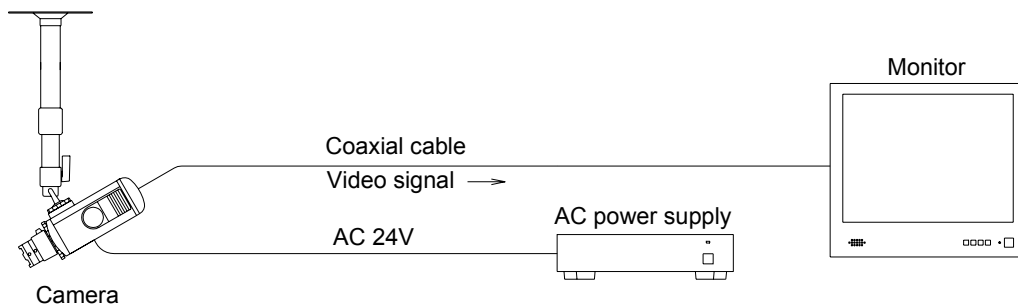

Fig. 3-3 24V AC System

#### 3) 12V DC System

Power is supplied to the camera via a 12V DC power supply. Since 12V DC power supplies are usually used for sensor systems as well, cameras can be integrated with these to achieve relatively inexpensive systems. One drawback of such power supplies is that their direct-current power source does not allow them to be used for video signal synchronization and because of the voltage drop in long cable.

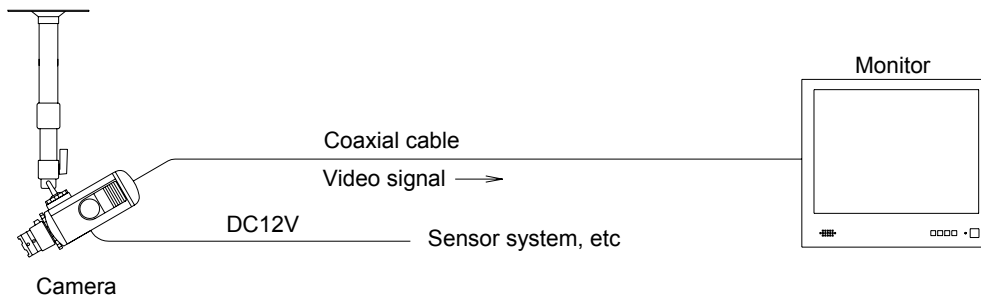

Fig. 3-4 12V DC System

#### 4) Single-Cable (Superimposing) System

By superimposing the video signal and the power supply over the coaxial cable, with the additional use of a camera drive unit, this system reduces the wiring between camera and camera drive unit to a single cable. However, while it simplifies cable installation, it is not suitable for use over long distances. Since the video signals superimposed on the power supply differ from normal signals, the format cannot be used for units transmitting signals by way of twisted-pair cables or for coaxial multiplex control systems. While most manufacturers offer single-cable systems, the superimposing method used tends to differ for each. This means that TOA cameras and camera drive units cannot be used in conjunction with those from other manufacturers.

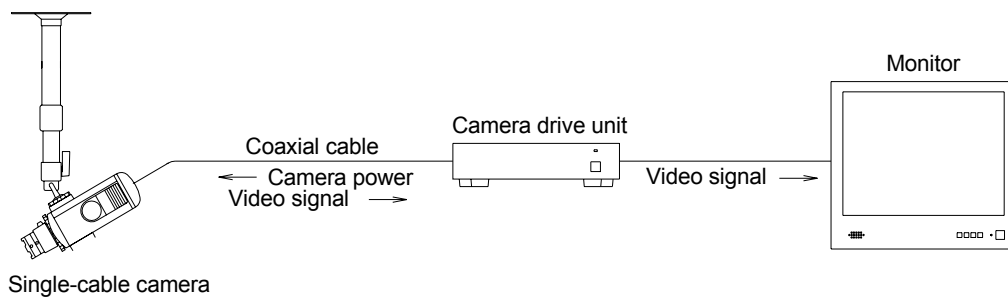

Fig. 3-5 Single-Cable System

### 3-3. Camera performance

The most important aspects of camera performance are its resolution and the minimum subject illumination. "Resolution" is the quantitative measure of how clearly an image is presented on the screen. It is measured both in horizontal resolution and vertical resolution.

Horizontal resolution is the maximum number of vertical black and white lines that can be clearly distinguished by the eye when the image is displayed on a screen. The color cameras used in surveillance systems generally offer horizontal resolution between 330 and 480 lines. If higher resolution is required, three-CCD cameras with horizontal resolution greater than 600 lines are recommended.

Vertical resolution is the maximum number of horizontal black and white lines that can be

seen in the reproduced image. Vertical resolution is constant and varies between 350 and 400 lines, depending on the scanning system. (NTSC, PAL or SECAM)

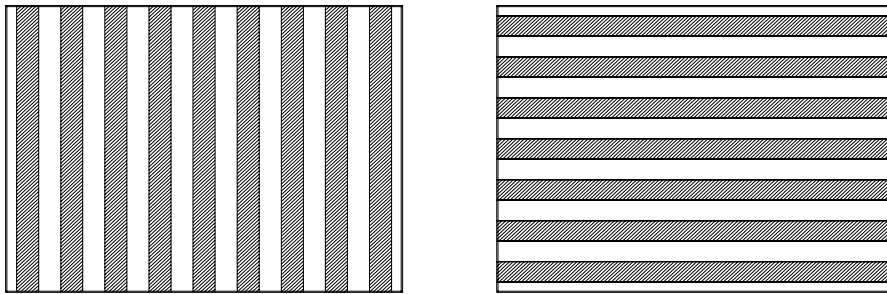

Fig. 3-6. Horizontal and Vertical resolution

“Minimum subject illumination” is the lowest intensity of illumination required for the camera too barely catch an image of the subject. At this minimum level of illumination, the subject cannot be clearly distinguished by the eye. The illumination permitting reproduced image to be clearly visible is called “recommended subject illumination”. Illumination is a measure of brightness and is measured in units called “lux” (lx). One lux (1 lx) is equivalent to 1 lumen of light flux falling on a surface with an area of one square meter. It is generally true that a brightness of 1 lx corresponds to the light of one candle viewed at a distance of one meter. Fig. 3-7 shows guidelines for brightness.

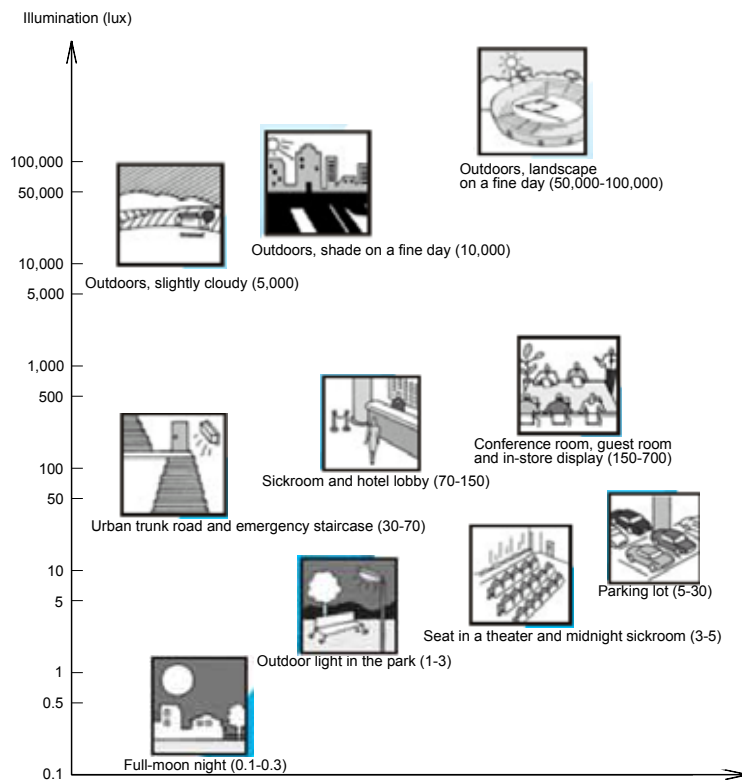

Fig. 3-7 Guidelines on Brightness

### 3-4. Camera functions

TOA color cameras incorporate various advanced functions that allow them to operate properly amidst various surrounding conditions. Models equipped with a DSP (digital signal processing) circuitry ensure wide dynamic range and offer stable color and clear image reproduction. The various camera functions offered are described below.

#### 1) Backlight Compensation (BLC)

When a window or other bright light source enters the screen, the adjustment of brightness to accommodate this bright area of the image may make the subject in front too dark. For example, when observing an entrance door in security surveillance applications, bright light entering from beyond the door may cause images of the faces of those entering to be completely darkened. The BLC function can be used to display the image of the subject at an appropriate brightness.

#### 2) Wide Dynamic Range

The wide dynamic range cameras becoming increasingly popular recently are designed to release their automatic electric shutters (AES) twice per frame, and then synthesize the resulting two images so that both the dark and bright subjects are shown in a way more easily visible.

While BLC cameras allow dark subjects to be seen clearly, wide dynamic range cameras help ensure clearer reproduction of both the dark and bright subjects in an image.

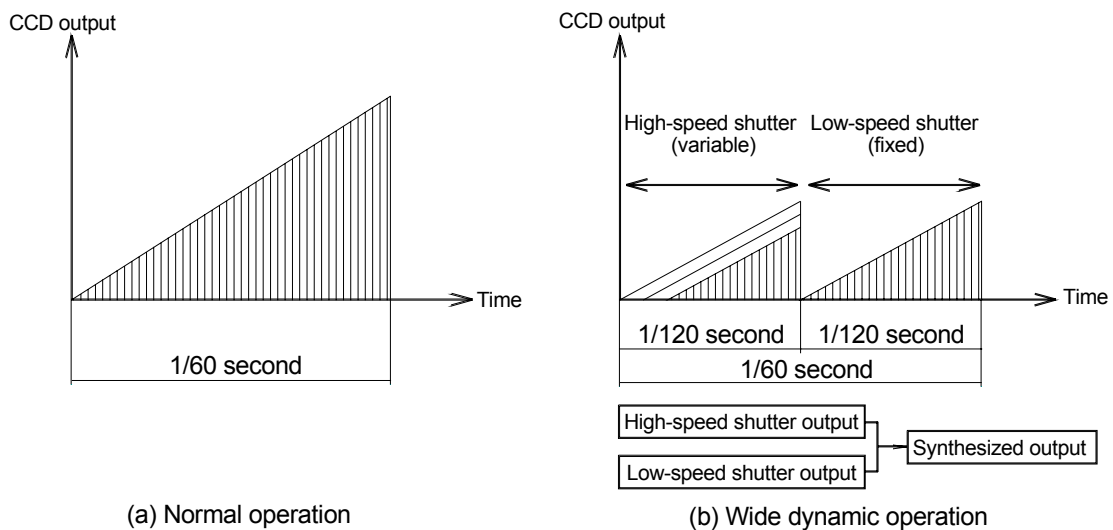

Fig. 3-8 Operation of Wide Dynamic Range (for NTSC)

#### 3) Image Enhancer

The enhancer function adjusts and sharpens the contours of the subjects for clearer image reproduction.

#### **4) White Balance**

The white balance function permits white objects to appear correctly within color image reproductions. When this adjustment is made automatically it is referred to as "automatic white balance" (AWB). Users can choose from two automatic white balance systems: an automatic tracking type (ATW) system that continuously analyzes the image for white balance adjustment during camera operation and AWB systems that adjust and correct white balance when the power is turned on.

In a candle flame, the different colors in different parts of the flame correspond to different high temperatures; usually measured using a scale of units called "Kelvin" (K). When a candle flame is observed through a surveillance camera, the white portions appear bluish white while lower temperature portions appear yellowish red. This represents the white balance corresponding to the temperatures of the light source, with color temperature for the standard white being 6500 K. Similarly, we may sometimes notice that the colors of our clothing we perceive indoors seem different when viewed outside in the daylight. Nevertheless, white always appears white to our eyes, regardless of the light source, because the human eye is capable of adapting to light source color temperatures. Surveillance cameras, in contrast, have less adaptability to color temperature and therefore reproduce colors differently depending on the light source. It is for this reason that white balance is required to adjust color tone without bias.

#### **5) Automatic Gain Control (AGC)**

This function adjusts video signals electronically in order to maintain a constant screen brightness. When an input signal of intensity exceeding the predetermined level is received, the gain is adjusted to prevent the signal from exceeding that level. Or, if the signal is too weak, it is boosted to the preset level. Thus, AGC is an automatic gain adjustment function for the purpose of keeping the signal intensity at a certain level. (Note: In the condition of low light, AGC operation can result in picture noise.)

#### **6) Automatic Sensitivity Adjustment (AES)**

This function maintains the brightness of the screen at a certain level by changing the shutter speed instead of relying on the aperture of the lens.

Note: AES cannot be used in areas where the power frequency is 50Hz, because the shutter mechanism is already utilized by the Flicker Reduction function.

#### **7) Flicker Reduction**

In areas where the power frequency is 50 Hz, light from fluorescent or mercury arc lamps may cause annoying screen flicker. This phenomenon is caused by a timing discrepancy between the standard 1/60-second shutter speed of the surveillance camera and the 1/50-second-flicker cycle of such lamps. Setting the shutter speed at 1/120-second can

suppress these flickers, although it may also make the screen a little darker.

### 8) High-Sensitivity Accumulation Function

This function makes the shutter speed slower than normal to allow the camera to accumulate images over a longer period of time, thereby enabling color images of subjects to be produced even in dark places. Enabling this function may cause noise, after-image or frame loss on the screen. When the camera is in an extremely dark place, this function can be used in conjunction with the Day & Night function described in the following subsection.

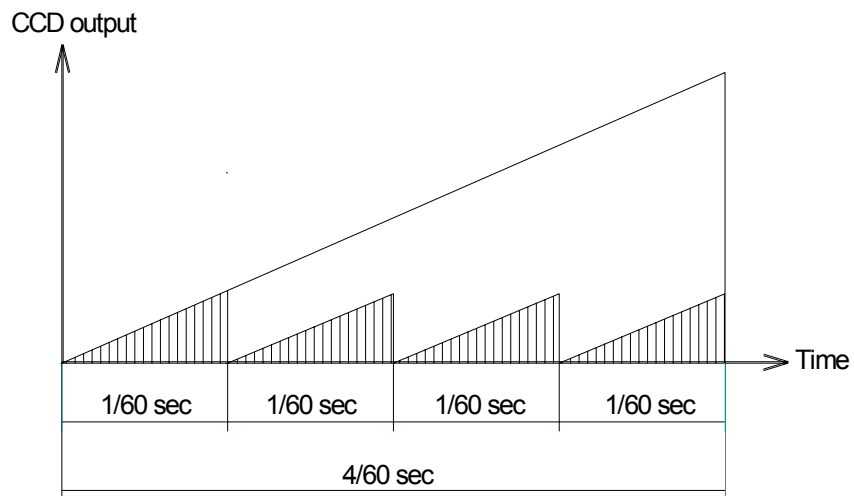

Fig. 3-9 Operation of High Sensitivity Storing Function (NTSC system)

### 9) Day & Night Function

When the camera is used in a place darker than 1 lux, the Day & Night function and the High-Sensitivity Accumulation function can be used together. To use the Day & Night function under dark conditions, remove the infrared cutoff filter located in front of the CCD, so that an infrared emitter is used as the light source for monitoring subjects.

Note: With this arrangement, even color cameras will generate monochrome images at night.

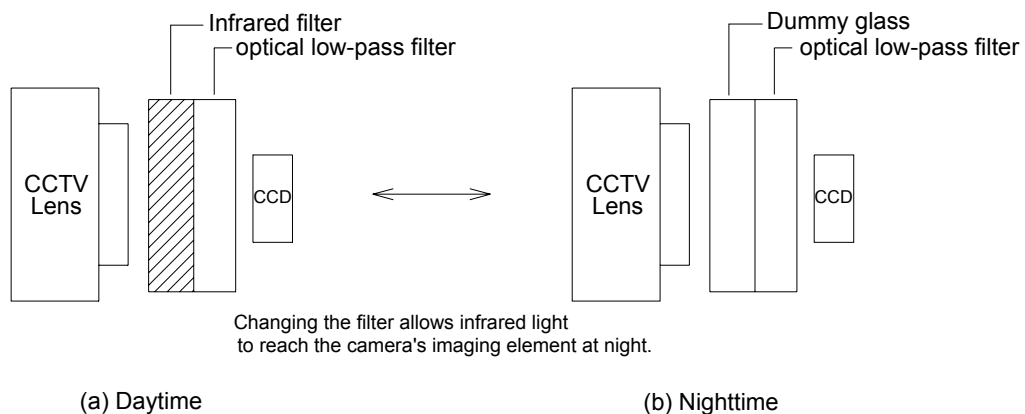

Fig. 3-10 Operation of the Day & Night Function

## 10) Privacy Masking Function

Taking privacy issues into consideration, up to four image subject positions can be masked on the screen, so that places like the windows of apartment buildings that must not be photographed can be exempted from surveillance.

Note: Privacy masking provides for camera movement tracking and scalability for zoom.

## 11) Other useful functions include:

- (a) 2X Electronic Zooming
- (b) Camera Title Display, which displays the name of the location under surveillance on the current screen.
- (c) Screen Reversing, which corrects inverted or reversed images.

### 3-5. Synchronization methods

"Synchronization" refers to the timing with which video images are scanned. The timing of scanning the screen from left to right is called "horizontal synchronization", while the method of scanning from top to bottom is called "vertical synchronization." The frequency of the horizontal synchronous signal is either 15.734 kHz (NTSC) or 15.625 kHz (PAL) and that of the vertical synchronous signal is either 59.94 Hz (NTSC) or 50.00 Hz (PAL).

When using a switcher to select among multiple video signals, failure to synchronize these signals correctly may cause annoying momentary disturbances of the screen with each switch. There are three different types of camera synchronization: internal synchronization, external synchronization and line lock synchronization. The camera may be set to use any of these methods.

#### 1) Internal Synchronization

Scans the video signal using the timing of the synchronous signal generated by the cameras built-in synchronous signal generating circuit. This method does not allow coordination with other cameras.

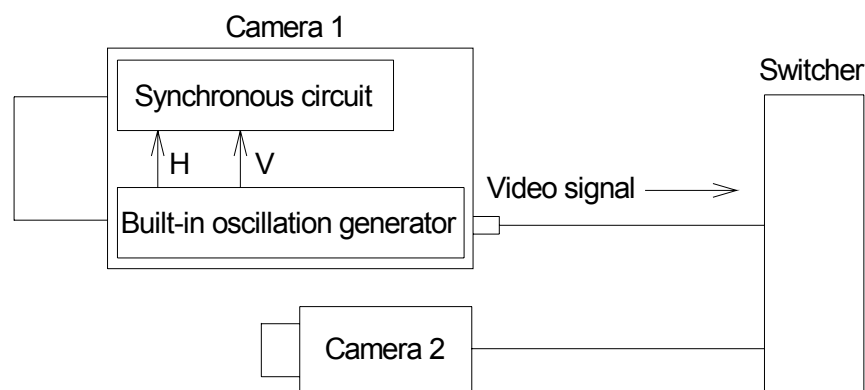

Fig. 3-11 Internal Synchronization Method

## 2) External Synchronization

Sends the camera the reference synchronous signal generated by an external synchronous signal-generating device. This method adjusts the scanning timing (synchronization) of each camera by supplying the same synchronous signal with identical timing. There are two methods of external synchronization: vertical external synchronization and gen-lock synchronization.

### (a) Vertical External Synchronization

Vertical external synchronization superimposes a vertical synchronous signal on the video signal. This method eliminates the necessity of additional cables for synchronization, making it easier to achieve synchronization.

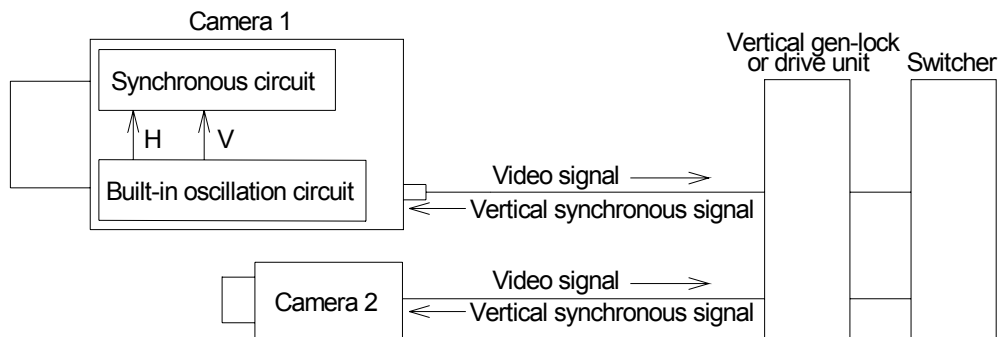

Fig. 3-12 External Synchronization Method

### (b) Gen-lock Synchronization

For Gen-Lock Synchronization, the camera's gen-lock input is connected to signals from other cameras to synchronize them. This kind of synchronization requires connection via two coaxial cables.

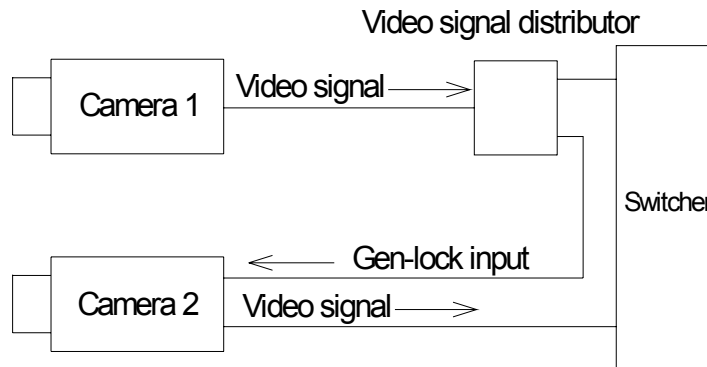

Fig. 3-13 Gen-Lock Synchronization

### 3) Line Lock Synchronization

This method adjusts the vertical synchronization by taking advantage of the fact that the 60 Hz frequency of the camera's AC power supply (commercial power supply) is nearly identical to the frequency of vertical synchronization. While this method permits easy synchronization by using a power supply of the same phase, it cannot be used in areas where the power frequency is 50 Hz instead of 60 Hz.

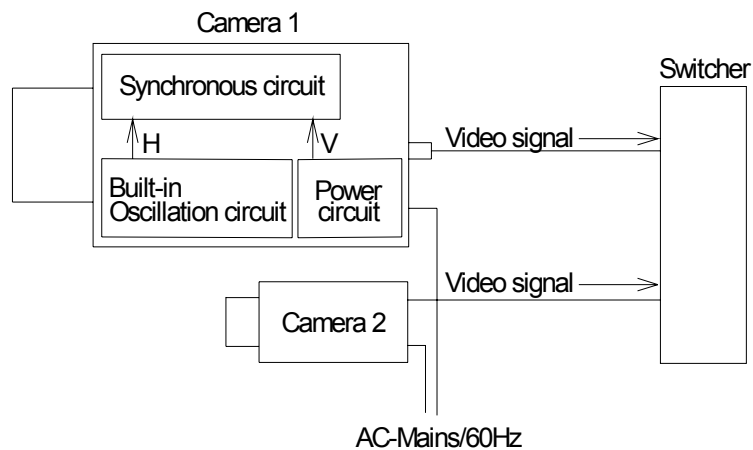

Fig. 3-14 Line Lock Synchronization System

Note: Non-synchronous cameras can be used in a system that utilizes a "Digital Video Signal Processor". The DVSP performs "Time Base Correction" to the input signals with the result that all the input signals become synchronized.

### 3-6. Camera mounts

#### 1) Mount

Cameras are usually mounted on walls or ceilings in indoor applications and on walls or poles in outdoor applications. In normal surveillance systems they are usually installed 3 to 5 meters above the floor, making them difficult to reach but allowing relatively easy access for inspection and service.

Camera mounts should be selected carefully based on the camera's size and weight, as well as its housing, taking into account weight limits and connector locations.

#### 2) Motorized Pan/Tilt Head

Motorized pan/tilt heads are used to move cameras to provide wider coverage of the area under surveillance. They can be rotated by remote control both horizontally and vertically. Horizontal rotation is called "Pan" and vertical rotation "Tilt."

"Auto-pan" allows the pan/tilt head to repeat the same panning pattern. Select the type of pan/tilt heads with weight limit capacities appropriate to the camera and lens to be mounted. There are both indoor and outdoor use types.

## 4. Lens Selection

### 4-1. Angle of view settings

The angular range covered by a camera is referred to as its “angle of view” and is determined by the focal length of the lens and the size of the imager (CCD) on which the picture is formed.

Note: For multiple lenses with identical focal lengths, the angle of view will not match if the size of the cameras CCD is different.

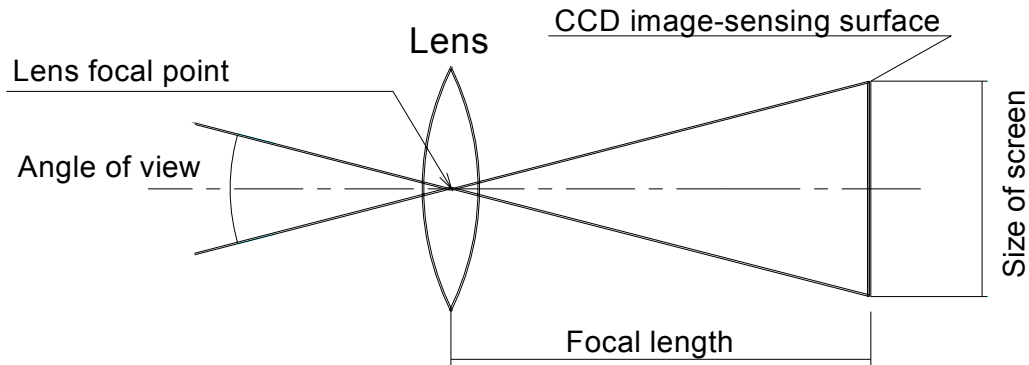
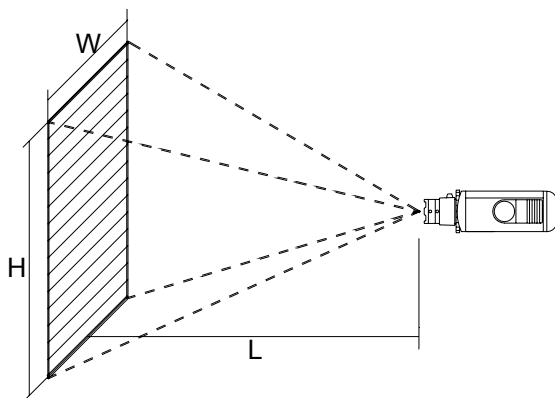

Fig. 4-1 Angle of View

CCD screen sizes are available in 1/4", 1/3", 1/2" and 2/3" types, measured based on its diagonal dimension. This difference in size makes almost no difference in terms of performance, but it does change the range of the view field.

Formulas for calculating field range



1/3" Type:

$$W = 4.8/f \times L \text{ (m)}; H = 3.6/f \times L \text{ (m)}$$

1/4" Type:

$$W = 3.6/f \times L \text{ (m)}; H = 2.7/f \times L \text{ (m)}$$

W: Width of subject

H: Height of subject

L: Distance between subject and camera

f: Lens focal length (mm)

Fig. 4-2 Types of Lens and View Field

The angle of view is expressed by the following formula:

$$\theta = 2 \tan^{-1} \left( \frac{l/2}{f} \right)$$

$\theta$ : Angle of view

l : Effective dimension of CCD(mm)

f : Lens focal length(mm)

The angles of view for different lenses are listed in the specification sections of catalogs. Generally these are as shown in Table 4-1.

Table 4-1. Angle of View

Type of lens	Angle of View (Horizontal)	Angle of View (Vertical)
Standard lens	30 – 40°	20 – 30°
Wide angle lens	55 – 60°	45 – 50°
Super wide angle lens	Over 60°	Over 70°

#### 4-2. Lens mount

The part connecting the lens to the camera is referred to as the “lens mount.” There are three types of mounts: C mounts, CS mounts and bayonet mounts. If a lens mount type does not match the camera requirement it will not be able to mount the lens to the camera properly.

C mounts and CS mounts have the same thread pitch and diameter. The only difference between the two is in the flange back (the distance from the mounting face to the CCD image-sensing surface) which is 17.526 mm for C mounts and 12.5 mm for CS mounts.

Note: CS mounts are shorter than C mounts, but C mount lenses can be mounted on a CS mount camera using an adapter.

As technological progress has made cameras increasingly smaller, CS mounts with their shorter flange backs are becoming more popular. The bayonet mount is often used for 3-CCD type cameras and has no interchangeability with either C or CS mounts.



Fig. 4-3 Lens Mount

#### 4-3. Auto-iris lens

Cameras equipped with an “auto-iris” function automatically adjust the aperture (iris opening) to match ambient brightness in order to maintain the brightness of the picture on the screen at a certain level. Lenses with manual aperture adjustment and without auto-iris are also available for use in windowless warehouses or other places where brightness does not change over time.

The two types of automatic aperture lenses include the Video type and the DC type (to be selected according to the camera specifications). The video type adjusts the aperture opening based on the video signal (supplied to the lens) as it is analyzed within the lens electronics. In the DC type, analysis is conducted by the camera microprocessor to send the DC control voltage to the lens. These two types offer very similar performance, but the DC type is less expensive .

If a camera uses a manual iris lens and is equipped with AES (a function that maintains a constant screen brightness level by adjusting the shutter speed), then it picks up scenes the same way as an auto-iris camera does. The AES function cannot be used in areas where the power frequency is 50 Hz and fluorescent or mercury arc lamps are used as the light source. In such cases the shutter function will already be in use for reducing flicker.

#### **4-4. Types of lenses**

The following types of lenses are usually used for surveillance cameras:

##### **1) Fixed Focus Lens**

This type of lens offers a lineup of standard, wide-angle and super-wide-angle versions, all with a fixed angle of view.

##### **2) Varifocal Lens**

A zoom lens that is manually adjusted is referred to as a “Varifocal” lens. Although this type of lens cannot be remotely controlled, its focal length can be adjusted manually when the camera is installed. This eliminates the need to select a specific lens, making it more convenient and versatile than fixed focal lenses.

##### **3) Motorized Zoom Lens**

This zoom lens can vary its focal length to permit subjects to be displayed in close-up or wide-angle. The focal length ratio between the telescopic end to the wide-angle end is referred to as the “zoom ratio”. Any given zoom lens is generally described as a “###:1 (##x) zoom lens” to express this ratio. The greater this ratio, the more range you have to change the size of the image. The motorized zoom lens has a built-in motor for changing the focal length and can be remotely controlled. Cameras with motorized zoom lenses are normally used in combination with motorized pan/tilt heads, with their zooming and focusing (iris) operations controlled via a remote control unit.

##### **4) Aspherical Lens**

The radius of the surface of this lens is not fixed, which has the advantage of minimizing image distortion in peripheral areas of the lens. In addition, an aspherical lens can offer images that are brighter relative to its size (that is, allows it to be a lens with a smaller aperture ratio).

### 5) Pin Hole Lens

This is a kind of fixed focal-length lens usually installed behind a wall or in a ceiling to monitor the room through a small hole (with a recommended diameter of 3.5mm). Such covert cameras are useful in situations where building occupants might feel uncomfortable being monitored by a more obviously positioned camera.

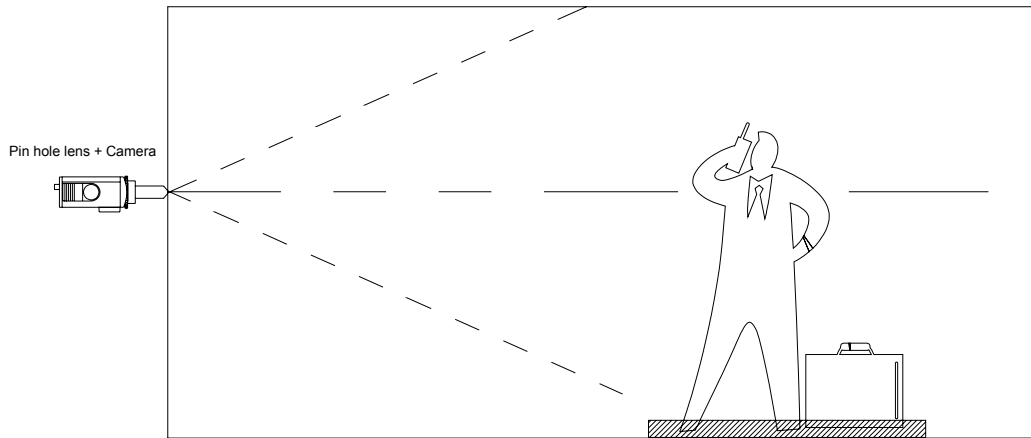

Fig. 4-4 Pin Hole Lens Installation

### 6) Prism Lens

This also belongs to the fixed focal-length lens category and is installed in a ceiling with only the prism portion exposed. This lens type can be used when it is preferable that the camera be invisible to building occupants.

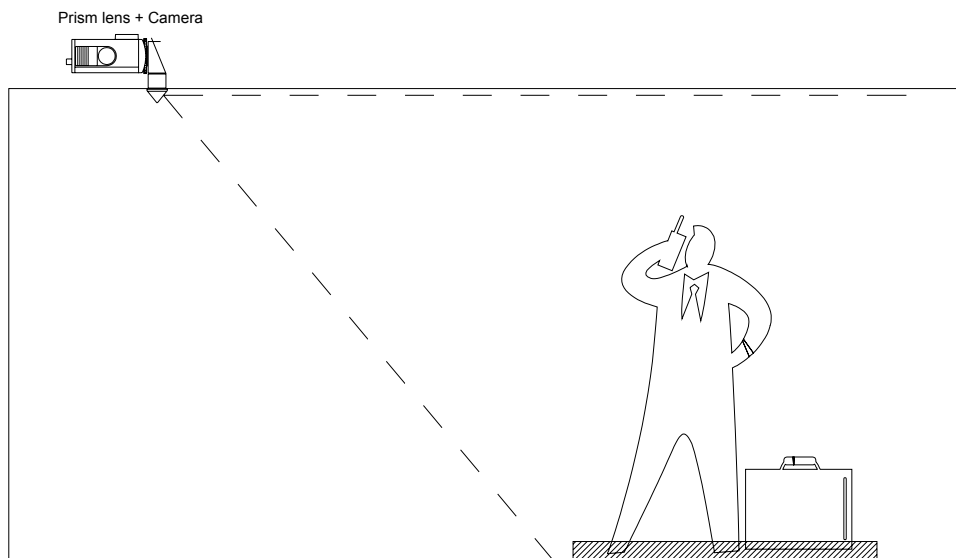

Fig. 4-5 Prism Lens Installation

#### 4-5. **Lens selection**

Selecting the proper lens type requires taking into consideration the location or position in which the camera will be installed and simulating the coverage area to be picked up in the camera image. Such simulations can be approximated roughly based on the field of view. Several points to bear in mind when selecting the proper lens are summarized below:

- 1) Wide-angle lenses provide a wide coverage area but subjects picked up in their images will be shown smaller.
- 2) Standard lenses show the subject larger but have a narrower coverage area.
- 3) To eliminate blind spots within the smaller the room, the wider the lens view angle needs to be.

To pick up detailed images from the whole of a wide area, either use multiple cameras or equip one or more cameras with pan/tilt heads and zoom lenses.

## 5. Monitor Selection

### 5-1. Monitors

Most CCTV monitors are designed solely for industrial applications and therefore do not include built-in TV tuners. Therefore, they cannot receive broadcast TV programs. When selecting a monitor, consider the positional relationship of the monitor to its operator to determine the proper size.

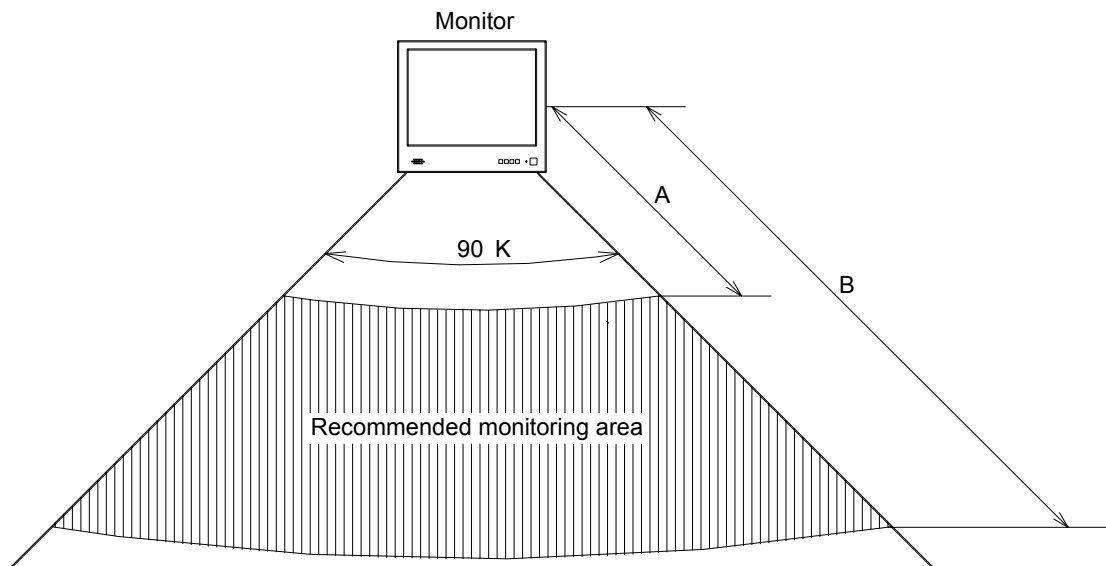

Monitor Size	Distance A, m (Ft.)	Distance B, m (Ft.)
9-inch type	0.9(3.0)	2.1(6.9)
14-inch type	1.0(3.3)	3.3(10.8)
21-inch type	1.2(3.9)	5.0(16.4)
29-inch type	1.7(5.6)	6.0(19.7)

Fig. 5-1 Monitor Size & Recommended Monitoring Distance

If a 4-segment split-screen display is to be used, Distance B should be shortened slightly since the images will be smaller. Smaller monitors such as 9-inch types are easy to install and can be mounted in equipment racks, but they are not suitable for observing the finer details of images displayed on the screen. If the size of a room does not permit a small 9-inch monitor to be installed in usable close proximity to the operator, a larger monitor should be selected.

Liquid crystal display (LCD) CCTV monitors for commercial applications are becoming increasingly available and more accessibly priced. Their remarkable features include space-saving thinness, lower power consumption and freedom from the danger of image burn-in. The advent of LCD monitors is also bringing solutions to problems that have proved difficult to solve using conventional CRT monitors. For example problems involving contrast, off angle viewing and display speed.

## 5-2. Reduced image scale on monitors

When the camera picks up a subject, the range of the coverage area varies depending on the lens selected. This is also true of the monitor and the size of the subject that can be viewed on the screen will differ depending on the size of the monitor. The actual size of a subject that can be displayed on a given screen can be calculated using the following formulas:

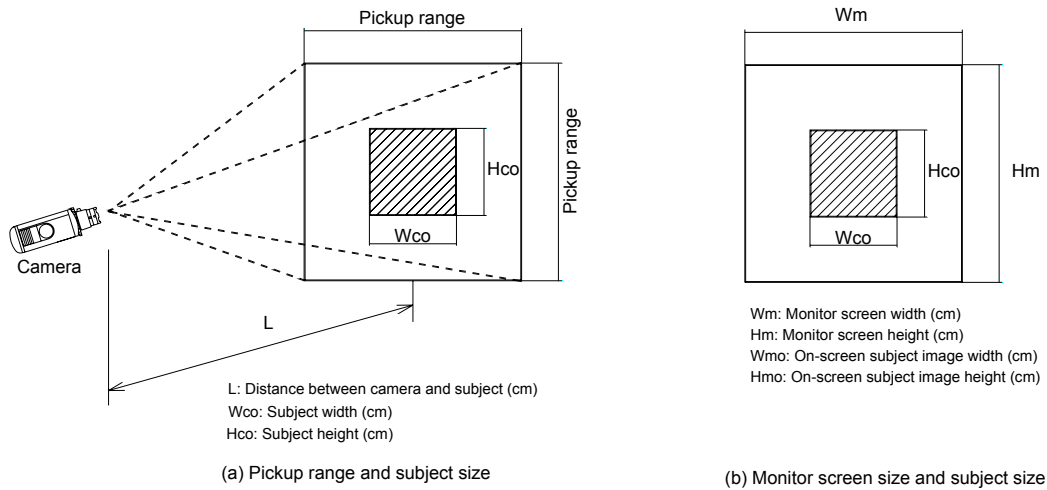

Fig. 5-2 Reduced Image Scale on Monitors

Table 5-1 Monitor Screen Sizes

Monitor Size	Height (cm)	Width (cm)
9-inch type	12	16
14-inch type	21	28
17-inch type	26	34
20-inch type	29	39
21-inch type	32	42
29-inch type	40	54

Formula (example for 1/3 type camera)

$$W_{mo} = \frac{f \times W_m \times W_{co}}{4.8 \times L \times 0.9}$$

W<sub>mo</sub>: On-screen image width (cm)

W<sub>m</sub>: Monitor screen width (cm)

L: Distance between camera and subject (cm)

f: Lens focal length (mm)

W<sub>co</sub>: Subject width (cm)

0.9: Overscan of monitor (cm)

$$H_{mo} = \frac{f \times H_m \times H_{co}}{3.6 \times L \times 0.9}$$

H<sub>m</sub>: Monitor screen height (cm)

H<sub>mo</sub>: On-screen image height (cm)

H<sub>co</sub>: Subject height (cm)

Values 4.8 and 3.6 are both constants for a 1/3" type camera. The constants for 1/4", 1/2" and 2/3" CCD types are as follows:

Table 5-2 Constants for Camera Types

CCD Size	Constant for Width	Constant for Height
1/4" Type	3.6	2.7
1/3" Type	4.8	3.6
1/2" Type	6.4	4.8
2/3" Type	8.8	6.6

**< Example >** : What will be the size of the image of a 170cm tall person when displayed on a 9-inch monitor when picked up from 10 meters away using a 1/3" type camera equipped with a 4mm focal length lens?

$$H_{mo} = \frac{4(\text{mm}) \times 12(\text{cm}) \times 170(\text{cm})}{3.6 \times 1000(\text{cm}) \times 0.9} = 2.52(\text{cm})$$

From the above calculation, it follows that the image of the person when displayed on the monitor will be approximately 2.5 cm.

### 5-3. Notes on monitor installation

Bear the following points in mind when installing monitors:

#### 1) Installation Location

Determine where to install the monitor. Multiple operator rooms may be required depending on the intended purpose of the system. The number of required monitors is determined by the size of the room in which they are to be installed and the number of operators.

#### 2) Monitor Installation Height

For around-the-clock surveillance applications, monitors should be positioned at a height slightly below operator eye level. Consider the operators' normal working styles as well. According to some statistics, four is the maximum number of monitors an operator can view effectively at one time. When multiple operators will view a single monitor, a large projector may be used. In any case, be sure to at least determine the maximum number of monitors that can be installed and the minimum number of monitors required for the system requirements.

#### 3) Room Brightness (Lighting)

If the monitor is placed in a dark room, operators may suffer eye fatigue. On the other hand, too bright a room exposed to the direct sunlight may negatively affect the view-ability

of the screen. Also, installing lighting equipment in close proximity to the monitor or installing lighting equipment with no directivity could result in annoying light reflections from the monitor screen.

#### **4) Ventilation**

Since monitors generate heat, they need to be positioned to allow for heat to escape. Overheating of the surveillance room in general should be prevented. Especially when monitors are placed on the operation table or in monitor racks, it is recommended that they be equipped with ventilating fans.

#### **5) Power Supplies**

Remember that a large surge of electric current flows into monitors when their power is turned on. When designing a system employing many monitors, it is important to ensure that the system has sufficient circuit breaker capacity, as well as delay circuits that can stagger power input.

Power supply voltage should be kept stable whenever possible. If voltage fluctuations cause image distortion on the monitor, it may be necessary to change the power supply layout or use a voltage stabilizer.

#### **6) Induction**

When multiple CRT monitors are installed side by side or one on top of another, magnetic fields may cause horizontal oscillation wave interference, possibly resulting in color variations or noise appearing on the screen. Placing a ferrous metal type plate between the CRT monitors can neutralize the influence of these magnetic fields. When using large CRT monitors side by side, mount them in a metal monitor rack.

#### **7) Image Burn-In**

If a CRT monitor continuously displays the same picture for a prolonged period of time (about 6 to 12 months on average, consult the CRT manufacturer for model specific information and recommendations), image burn-in may occur. To avoid this, take care to avoid continuously displaying the same image on the screen. In particular, bright images are more likely to cause burn-in, shortening the CRT life span.

## 6. Switcher Selection & Video Recording

As the number of camera's increases, the number of monitors also increases. Since there is a limit to the number of screens a single operator can view at one time and because space for monitor installation is also limited, the number of monitors can be reduced by switching camera outputs in sequence on a single monitor or by using multi-segment split-screen displays. Also, since operators cannot always view all screens, sensors connected to time-lapse VCR's or DVR's may also be required to capture unviewed images for later playback if necessary.

### 6-1. Sequential switcher

To view multiple camera outputs on a single monitor, switch the outputs displayed on the monitor in sequence or display them together on a split screen. A manual switcher is designed to allow manual switching among camera's images. An automatic sequential switcher switches the images at specified intervals.

When sequential switching is used, the screen can display only one camera output at a time, meaning that other camera images cannot be viewed simultaneously. In this case, important scenes could be missed or discovered too late. If, for example, 12 camera outputs are sequenced to display on a single monitor at 10 seconds intervals, the total amount of time to display images from all twelve cameras is 120 seconds. Therefore, the greater the numbers of cameras, the longer the sequence cycle interval. To prevent important scenes from one camera output from being missed while another camera output is being displayed, the switcher should be equipped to receive the sensor signal in the form of an alarm that instantly and automatically switches the display to the relevant camera image. Note that when switching among multiple cameras by means of the switcher, the cameras must be synchronized (see section 3-5 Synchronization Methods).

If three cameras are sequenced, the monitor screen will be switched as shown in Fig. 6-1.

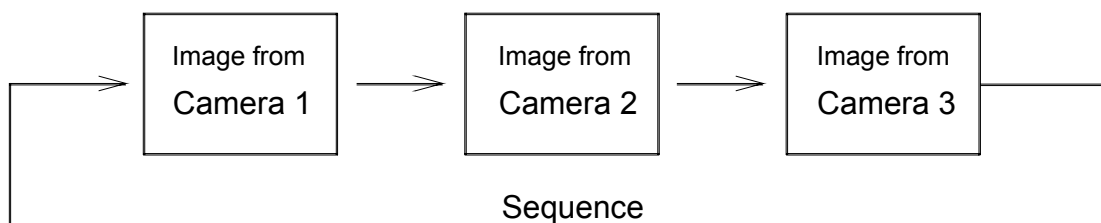
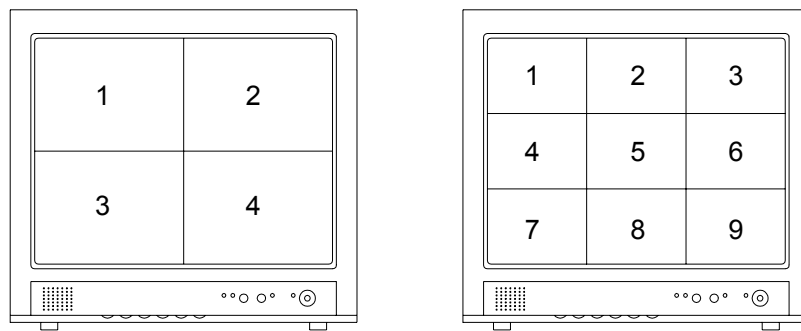

Fig. 6-1 Sequential Switching

### 6-2. Multi-viewer

A Multi-viewer has a split-screen display function that allows multiple camera images to be viewed on a single monitor. Either a 4, 9 or 16 segment split-screen display is possible. The larger the number of segments, the smaller each will be on the screen requiring use of a larger monitor. A Multi-viewer can also be connected to a sensor to switch the screen to a sensor-operated camera output.

Since the video signal is digitally processed, cameras need not be synchronized. Other versatile Multi-viewer functions include a screen freeze function and a 2X-zoom function that digitally magnifies part of the screen. Using a split-screen display, multiple camera images can be viewed simultaneously.



(a) 4-segment split-screen display      (b) 9-segment split-screen display

Fig. 6-2 Multi-viewer

### 6-3. Matrix switcher

For systems with multiple operator rooms, the “distributed method” was conventionally used by CCTV systems to distribute camera images to sequential switchers installed in each.

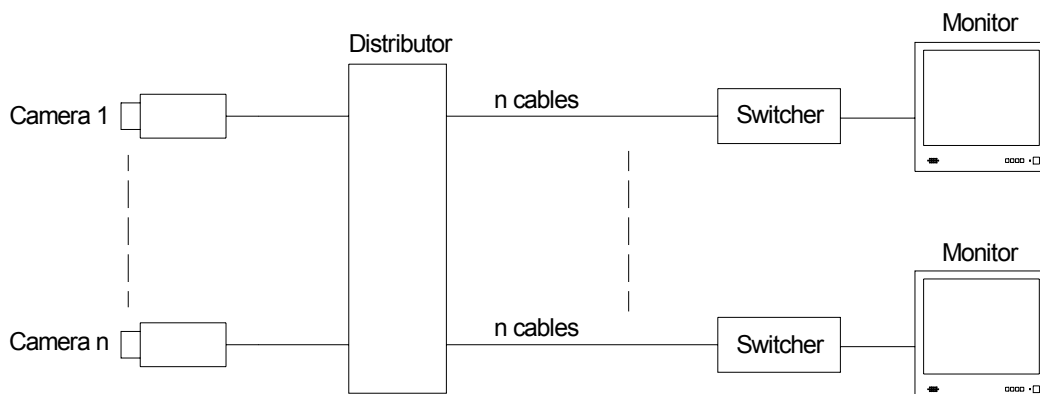

Fig. 6-3 Distributed System

Nowadays, however, to save cables for video signal transmission, a new Matrix Switcher control method that switches images at a matrix section has replaced the conventional method.

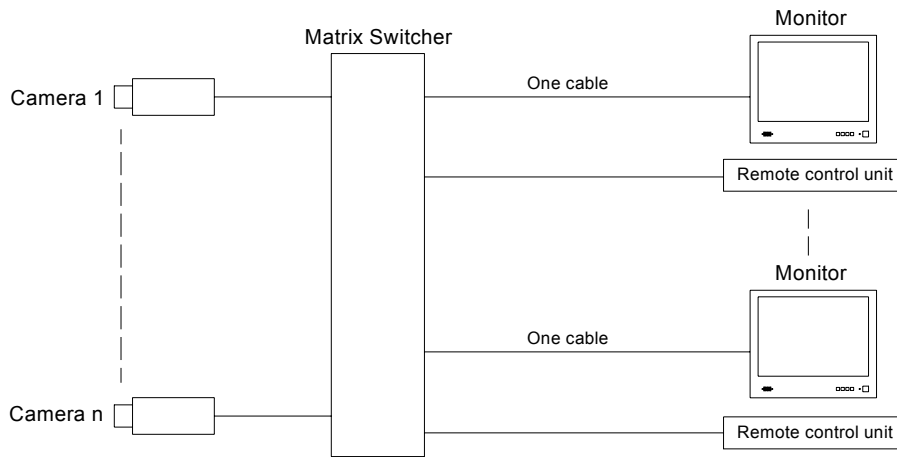

Fig. 6-4 Centralized System

The signal routing made possible by a Matrix Switcher can switch video signals manually or automatically. It can also be used to remotely control the zoom lenses and pan/tilt heads from remote control units installed in several locations. In systems employing a large number of cameras, the centralized system has an economic advantage over a distributed system.

#### 6-4. Multiplexer

Because Multiplexers include a frame recording function, they can be used in conjunction with a time lapse VCR or DVR to record 9 or 16 camera images on a single VCR or DVR in quasi-moving picture formats. The following table shows the recording differences between a Multiplexer and a sequential switcher.

Table 6-1 Frame Switcher Recording

		Sequential Switcher	Multiplexer (9 channels)
Normal Mode	Recording	Records by switching images at 1 to 60 second intervals	Records by switching camera at each frame
	Reproduction & Retrieval	Reproduces images as recorded, but necessary scenes may go unrecorded.	Selects camera to reproduce quasi-moving pictures at 3.33 frames/sec.
Time-Lapse Mode	Recording	Records by switching cameras at each frame, but frame loss may occur.	Records by switching cameras at each frame.
	Reproduction & Retrieval	Time is identifiable. Check picture frame by frame.	Select camera for reproduction. Easy retrieval.

To record images from more than one camera, either prepare as many recorders as there are cameras or connect one recorder to the sequential switcher or Multiplexer to record images displayed on the switched or split screens. Keep in mind, using the switcher or Multiplexer may involve the problems mentioned above, including missing recording of important scenes (sequential switcher) and image size reduction (Multiplexer).

A Multiplexer allows multiple images to be recorded by switching them frame by frame. Thirty frames (NTSC) or 25 frames (PAL) are transmitted per second from each camera, with one camera output being assigned to one frame and recorded in the frame recording. When reproducing images for playback, individual frames from the same camera output are retrieved and compiled into quasi-moving picture formats. With this method, all camera outputs are recorded and only those cameras required can be selected for reproduced playback. Recorded images can be displayed in sequential order, as well as on 4-segment or 9-segment split screens. Note that because this method has not been standardized, TOA models are not compatible with frame-switchers by other manufacturers. Take this into consideration when using a TOA multiplexer in combination with non-TOA time-lapse VCR's or DVR's.

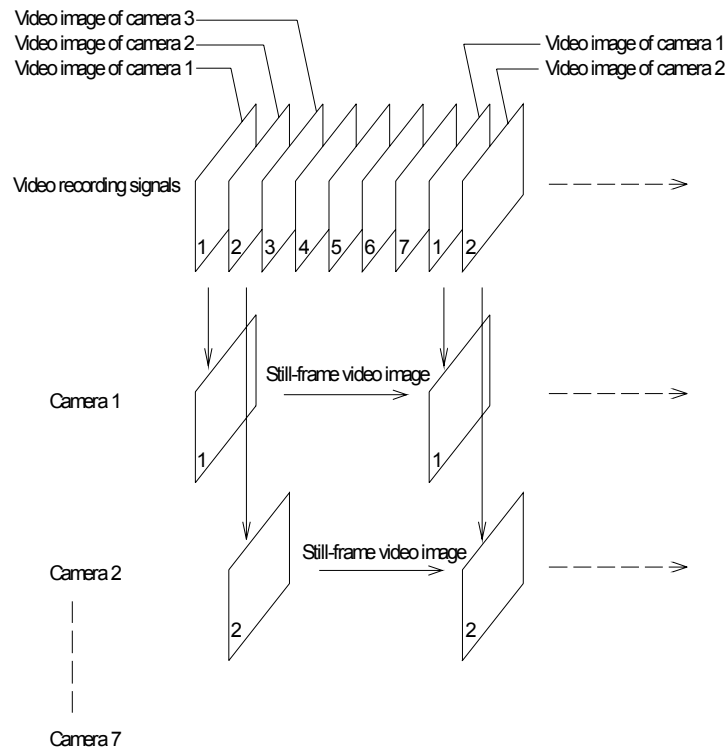

Fig. 6-5 Operation of Frame Recording (when 7 cameras are connected)

## 6-5. Time-lapse VCR recordings

### 1) Recording

VCRs are used when:

- (a) Recordings should be kept as potential evidence of crimes or accidents.
- (b) An operator does not always attend monitors.
- (c) Performing remote surveillance.

In remote surveillance applications, if it is difficult to transmit images from places like elevators, then a VCR can be used to record surveillance images for reproduction only as needed. Either of the following methods may be used for this function.

(d) The tape is set in a recorder and recording takes place until the end of the tape is reached. The tape then automatically rewinds and is used again, overwriting the previous recording.

(e) Several tapes are prepared and used in rotation. In one typical example, seven 120-minute tapes are used in 24-hour mode, with each being replaced by the next at 8:00 AM each morning throughout the week.

This approach preserves video images for up to one week, since that is how long it will take until any given tape to come back into the cycle to be reused and overwritten.

Table 6-2. Recording Mode vs. Recording Interval

Time Mode	Recording time (T-120 is used)	Recording interval (Second)	Voice recording	Tape running
02	2 hours	0.017	Possible	Continuous running
06	6 hours	0.017		
18	18 hours	0.05		Continuous slow running
24	24 hours (1 day)	0.2		
48	48 hours (2 days)	0.4	Impossible	Intermittent running
72	72 hours (3 days)	0.6		
96	96 hours (4 days)	0.8		
120	120 hours (5 days)	1.0		
168	168 hours (1 week)	1.4		
240	240 hours (10 days)	2.0		
360	360 hours (15 days)	3.0		
480	480 hours (20 days)	4.0		
720	720 hours (1 month)	6.0		
960	960 hours (40 days)	8.0		

### 2) Searching for Specific Images

Inevitably it will be necessary to search for a particular segment of video recording for later playback. The larger a system becomes, the larger the number of VCR's and tapes will also become. Tapes themselves can be organized and labeled for later use based on their

recording time and location, but it can be quite difficult to search within any given tape for a specific event, especially if the event occurred over a short period of time. To facilitate such searching, some VCR's can record an alarm signal along with the video signal that sounds during playback.

Recent advances in digital video compression technology have also made it possible to record images onto media such as hard disks, DVD's, or DV tapes as digital data. Since these methods eliminate the need for cumbersome mechanical fast-forwarding and re-winding, searching is relatively easier than with conventional VCR recordings. It is also possible to record such data along with sensor information, so that alarm-activated scenes can be searched using a computer.

#### **6-6. Digital video recorders (DVR's)**

Digital video recorders (DVR's) are classified into three types depending upon the recording media used. These include hard disk drive (HDD) types, optical disk (DVD) types and combined DV cassette tape and HDD types. They can also be divided broadly into multi-channel types equipped with frame-plexer functions and one-channel types not equipped with such functions. Since digital video recordings also have their own life spans, recorded data must be backed up. Unlike time-lapse VCR recording, digital video recording uses compressed digital images offering the following advantages.

##### **1) Easy searching**

It is possible to locate and call up only those scenes tagged with alarm data, or to select particular scenes by specifying their recording date and time. Both functions allow desired scenes to be located more quickly and easily than was possible conventionally.

##### **2) Simultaneous recording and playback**

Video recording and playback can be performed simultaneously, a function that is not possible with time-lapse VCR recording. Recording does not stop even during playback. Using this function, images currently being recorded and reproduced can both be displayed simultaneously using a multiple-segment-split screen.

##### **3) High-quality video recording**

In digital recording, the fact that the original signal does not deteriorate allows for higher quality recordings. The deterioration of tape media and record/playback heads that are normal with time-lapse VCR equipment do not occur, allowing higher quality images with less variation in quality over time to be recorded.

##### **4) Easy data handling**

The digital nature of image data makes it easy to handle. Since every piece of information is recorded and stored as digital data, it can be input into a computer for editing or transmitted easily over a LAN or other network.

## 7. Sensor Type Selection

Camera surveillance systems are not always attended by operators keeping a constant watch on the events displayed on the monitors. For this reason, they may be outfitted with sensors to prevent important recorded scenes from being missed while operators are away, or to allow the system to operate more efficiently when switching among multiple camera outputs.

Sensor types include magnetic proximity switch types, shutter types, infrared types, glass-break types, passive types and ultrasonic types. Table 7-1 outlines the features of each of these.

Table 7-1 Sensor Types

Sensor Type	Operation
Magnetic proximity switch sensors	Comprised of a permanent magnet and a magnetic reed switch. The reed switch closes its contact when the permanent magnet is near and opens its contact if the magnet's magnetic field is removed. This sensor is usually used to detect the opening or closing of windows and doors.
Shutter sensors	Used to detect the opening or closing of large doors, shutter sensors include infrared, magnetic and mechanical types. The infrared type consists of a light transmitter/receiver device and a reflective sheet that returns the light sent out by the transmitter portion back toward the receiver portion.
Infrared sensors	Comprised of unit that transmits a beam of near-infrared light and a unit that receives that light. If the infrared light between the two units is cut off, the sensor detects this interruption and outputs a signal.
Glass break sensors	Detects cutting or breakage of glass by an intruder. Vibration types are attached directly to the window glass, while sound types are mounted to a nearby wall or ceiling.
Passive sensors	Passive sensors detect changes in far-infrared rays when a human being or animal moves within the sensing area.
Ultrasonic sensor	Ultrasonic sound waves are transmitted and reflected from moving objects the speed of which alters the frequency of the returning sound waves. The receiving equipment sends an alert signal when such frequency variations are detected.

### 7-1. Infrared sensors

An infrared sensor is comprised of a light transmitter and a light receiver. When the near infrared light beam from the transmitter is interrupted by the passing of an intruder, a relay contact closes causing the sensor to send an alert signal.

The properties of the near-infrared light used in such systems are close to those of light in the visible spectrum, meaning that they can incorporate most types of optical equipment without any modification. Near-infrared light also causes a strong photoelectric effect on the receiving unit and it is therefore easy to work with.

As beams of light travel through the air they gradually weaken, a phenomenon called "attenuation." Attenuation is caused by two different factors, "absorption" and "scattering." Absorption occurs when radiation energy is transformed into another kind of energy;

scattering occurs when the radiated light encounters small particles in the air that change its direction of travel in small increments. Attenuation occurs in the air even when the air does not contain dust or vapor. Near-infrared light, however, can travel longer distances than visible light (depending on the specific wavelength) with less haze-caused attenuation because its wavelength is longer than that of visible light.

An infrared sensor system is generally comprised of a light transmitter unit that transmits a beam of infrared light and a receiving unit that receives the light and processes the resulting signal. These two units can be installed on the same surface (reflection type) or on opposite surfaces (opposing type). Figure 7-1 shows the basic equipment configuration for the opposing-type system.

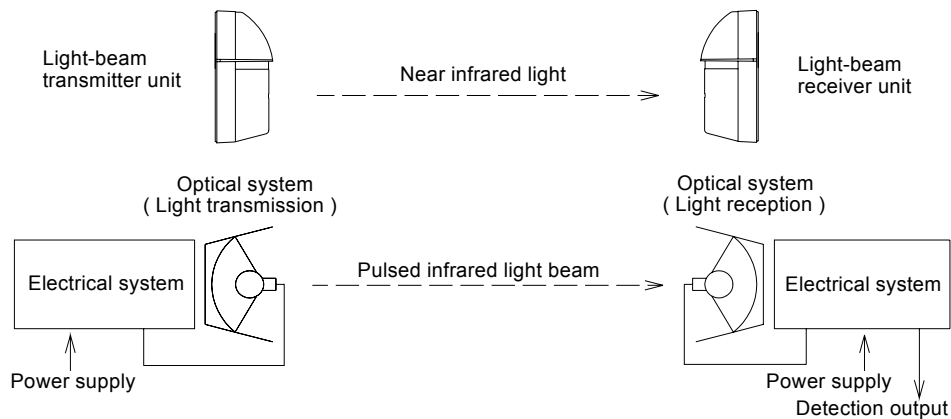
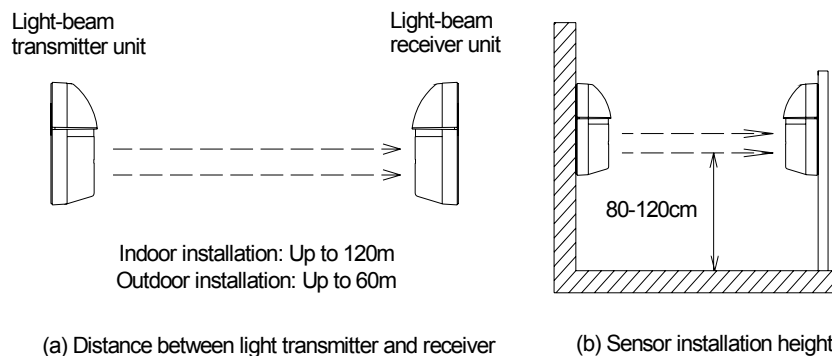

Fig. 7-1. Equipment Configuration for an Opposing-Type Infrared Sensor System

Opposing-type infrared sensors are available in 20-, 40- and 60-meter versions, depending on the size of the area to be monitored. They can be installed between 80 and 100 centimeters from the floor surface. The space between light transmitter and receiver must always be completely clear of any obstructions.

It is also important to ensure that the space between the light transmitter and receiver is not directly exposed to strong light sources such as sunlight or headlights. The entry of the strong light into the light axis of the equipment over an extended period could reduce its life span.



(a) Distance between light transmitter and receiver

(b) Sensor installation height

Fig. 7-2. Infrared Sensor Installation Example

## 7-2. Passive sensors

Passive sensors detect the presence of an intruder by sensing changes in ambient temperature. Because such sensors are susceptible to wind, they are not appropriate for outdoor applications.

All substances with a temperature higher than absolute zero radiate some amount of infrared radiation. Far-infrared light cannot pass through the materials used in a building's walls, floors or windows. Although glass appears transparent, it does not allow infrared light with wavelengths longer than  $2\mu\text{m}$  to pass through it.

A passive sensor's detector utilizes a current-collection effect generated when electric charge induction resulting from slight temperature changes is caused by a condenser or other dielectric unit receiving the infrared rays. The sensor collects an electric charge by filtering those far-infrared rays between 7 and  $14\mu\text{m}$ , which is the range of wavelengths radiated by the human body. The detection area to be monitored (specific spots, planes or three-dimensional areas) determines the layout and number of optical equipment pieces. Factors such as mounting position and wall/ceiling height determine the detection area and require the selection of an appropriate sensor.

An alarm zone (the range of the spread of the light) made up of a single optical system is referred to as the "sensing zone." If an intruder enters this sensing zone, the sensor's detector picks up the far-infrared rays radiated from the intruder, causing the amount of electric charge induced in the detector's current collection unit to change. When this change exceeds a predetermined level, the sensor outputs an alarm signal. The detector is set to be most sensitive to speeds within 0.4 to 1 meter per second (1.5 – 4 kilometers per hour), which is the usual speed range of intruders attempting to walk stealthily.



Fig. 7-3. Passive Sensors

## 7-3. Motion detectors

Motion detectors react to any change in brightness within the detection zone set on the monitor screen, without using external sensors. This type of sensor is particularly useful in locations where it is difficult to install sensors or cables in the monitored location. One drawback of this type of sensor, however, is that it often fails to function accurately and cannot be used for many outdoor applications. Some multiplexer's come with a motion detection function.

## **8. Remote-Controlled Surveillance and Network Cameras**

### **8-1. Remote-controlled surveillance**

If the distance between a camera and a security room is over 3 kilometers (1.9 miles) or if coaxial cables cannot be installed for some reason, then surveillance must be controlled remotely. If it is difficult to install a coaxial cable, systems using laser, near infrared rays, spread spectrum or mobile telephones might be considered. Care must be taken to secure the power supplies of the equipment employed. Connection may also be achieved using a LAN or lines furnished by Internet communication providers.

#### **1) Laser**

This method uses a laser beam to transmit a video signal over a distance to a receiver. Since laser light offers excellent linearity, it can transmit signals over distances of 3 – 5 kilometers (1.9 – 3.1 miles), although it is necessary that there be no obstacles in between and that the transmitter and receiver are fixed securely in place.

A laser system is not susceptible to rain or snow, but fog, birds or insects may interfere with video transmission. Also, the laser-light generating device must be installed so as to prevent the potentially damaging laser light from entering people's eyes.

#### **2) Near-infrared light**

In this method, video signals are transmitted between a light transmitter and a light receiver by means of infrared light rays. Although this method is less costly than the laser system, the transmission distance is much shorter at 300 – 800 meters (328 – 801 yards). As with a laser system, signals cannot be transmitted past obstacles or if the transmitter and receiver are not fixed securely in place.

An infrared system is not susceptible to rain or snow, but fog, birds or insects may interfere with video transmission. Infrared light is not dangerous to the eyes or other parts of the human body, so the system can be installed even in locations where people might be exposed to it.

#### **3) Spread spectrum**

Also called the "SS radio transmission method", this system uses radio waves in the 2.4GHz ISM band to transmit video signals over distances 1 – 2 kilometers (0.62 – 1.124 miles). Although such video transmission cannot be performed if there are any obstacles in between, the use of radio waves instead of visible or near-visible light means that the transmitter and receiver do not need to be securely fixed in place.

#### **4) Mobile telephone**

Video signals are transmitted via dedicated equipment connected to a mobile telephone. This system can be used everywhere provided the mobile telephone is within good recep-

tion range. The monitor at the other end also requires a telephone line. However, since such images are compressed,\* they may suffer frame loss or mosaic images depending on transmission conditions. Further, since this method entails telephone fees, it is usually not suitable for constant monitoring applications. There are also some countries in which mobile telephones cannot be used.

### **5) Telephone line**

Video signals are transmitted using a dedicated transmitter device connected to a telephone line. As with transmission by mobile telephone, the image data is compressed.\*

### **6) Fiber optic cable**

Fiber optic cables allow video signals to be transmitted over distances up to 3 kilometers (1.86 miles), with the added advantage that the transmission path is not affected by external noise sources. Because video signals are transmitted “as is” (i.e. not compressed), a relatively wide frequency band up to 50MHz may be permitted, which in turn requires a quartz-clad cable (such as a GI cable). Fiber optic cables clad in ABS resin cannot be used.

\*Video signal compression formats include the following:

#### **(a) JPEG**

Used to compress still-frame video image data at compression rates from 1/10 to 1/100.

#### **(b) M-JPEG**

Compresses moving picture data recorded on each frame using the JPEG method to continuously record compressed data or reproduce decompressed data.

#### **(c) H.261/263, MPEG**

An image data compression method that achieves highly efficient compression by eliminating and encoding time-related and space-related redundant portions of video data.

The general MPEG standard encompasses several specific formats including MPEG1, MPEG2, and MPEG4.

## **8-2. Network camera system**

### **1) Network**

Cameras may be connected to an existing data network to transmit video data over the network’s lines or to control surveillance remotely using a personal computer connected to those lines or accessing the network over the Internet. Monitoring video signals over networks built on the already widely used Ethernet network standard is very likely to become one of the most popular options. Types of network include LAN’s (Ethernet including 10BASE, 100BASE and 1000BASE types, FDDI, ATM, etc.) and WAN’s (private lines, data communication networks, wide area LAN services, VPN (Internet), etc.).

## 2) Equipment configuration

Equipment is connected directly to the LAN or other independent network to control or monitor video images and/or speech audio. A network system can be combined with a conventional system using: network cameras that connect directly to the network; a network video transmitter that can send composite analog signals over the network and a network video receiver that can receive analog signals and convert them to composite analog signals.

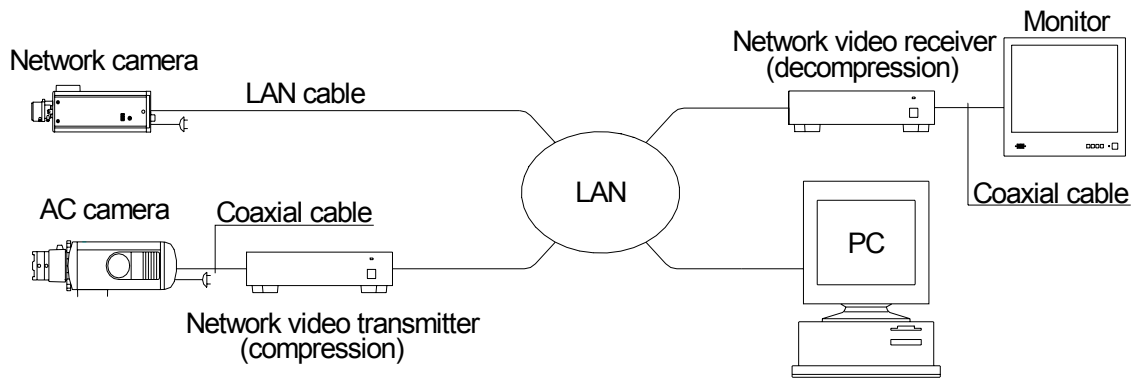

Fig. 8-1. Network Camera System

A network camera system compresses images and can transmit and receive that compressed data over the LAN or other network using protocols like TCP/IP. Advantages of the network camera system include easy camera expansion and movement, image viewing using a PC and the ability to control cameras remotely. It is also possible to incorporate a data router into the system to monitor remote locations over ISDN or Internet lines.

Data compression methods generally used include JPEG, M-JPEG, H.261/263, MPEG-2 and MPEG-4. However, since these are usually incompatible with one another, be sure to check the system's data compression methods and PC viewer software carefully before operating such a system.

When video surveillance is to share the LAN with other network systems (a company's PC network, for example), try to design the network with sufficient bandwidth that minimizes the negative influence of the image data transmission, since the data involved tends to be relatively heavy.

Also note that the limitations of the network itself may restrict the number of transmittable image frames, picture quality and screen size.

When transmitting image data over the Internet, equip the system with a password and/or encrypt the data to prevent unauthorized access.

## 9. Video Signal and Control Signal Transmission

### 9-1. Coaxial cables

Coaxial cables with impedance of 75Ω are normally used for video signal transmission.

Coaxial cables are identified using following symbols:

RG - # # / U

RG: Radio Grade, High frequency cable classification symbol

#: Type number

U: Universal, General use

Table 9-1 High Frequency Cable (Example)

	RG-59/U	RG-6/U	RG-11/U	RG-15/U
Cable outer diameter (mm)	5.9	6.8	10.3	13.8
Conductor diameter (AWG)	22	18	14	14
Characteristic impedance (Ω), nominal value	75	75	75	75
Attenuation (dB/km), 10MHz	29.5	23.6	11	13

#### 1) Maximum coaxial cable lengths

Table 9-2 shows maximum video signal transmission distances. Signal transmission is still possible even if the distance exceeds the indicated limits, but the longer the coaxial cable length, the more resolution will deteriorate. Note: Even if the cable length does not exceed the indicated limits, video signal transmission can still fail or be adversely affected if it is subject to interference by AC power supplies or other electromagnetic field sources. Use the guidelines in Table 9-2 to determine approximate usable cable lengths.

Table 9-2. Maximum video signal transmission distances (Example)

Coaxial cable type	Maximum cable distance, m (yard)	Maximum cable distance, m (yard) <When cable compensator is used.>
RG-59/U	250 (273)	2,000 (2,187)
RG-6/U	500 (547)	2,400 (2,625)
RG-11/U	600 (656)	2,400 (2,625)
RG-15/U	750 (820)	3,000 (3,281)

#### 2) Cable compensator

Transmitting video signals over long distances may degrade image quality and make the on-screen image appear out of focus, resulting in deteriorated resolution.

A cable compensator enhances the contours of subjects to compensate for such image degradation, thereby allowing video signals to be transmitted over longer distances, as shown in the right column of Table 9-2.

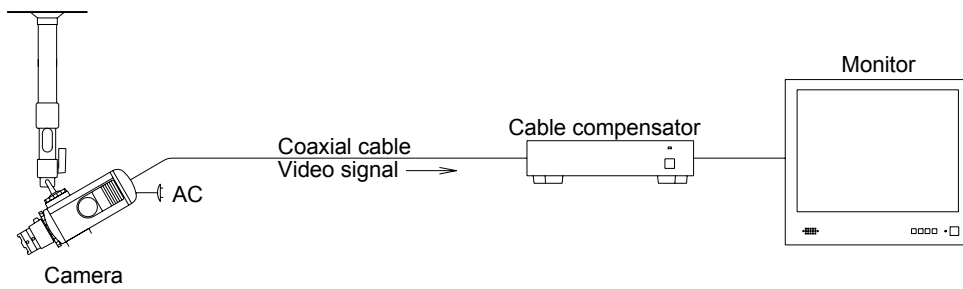

Fig. 9-1. Cable Compensator

### 9-2. Twisted-pair cable transmission

In elevators or other locations where a coaxial cable would be difficult to install, a good option is to change the impedance using a video transformer and transmit video signals over a twisted-pair cable. A twisted-pair cable has the advantage of reducing the influence of noise induced from external equipment. However, this method cannot be used for single-cable cameras.

(An example would be power over coax type.) Camera looks like ACmain type that is not our line-up.

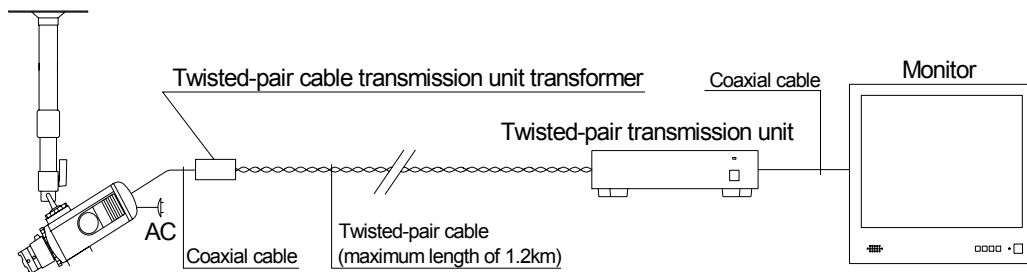

Fig. 9-2. Twisted-pair Cable Transmission

### 9-3. Control signal circuits

Signals used to control lenses or pan/tilt heads remotely are referred to as “control signals”. Since many different types of signals need to be transmitted, depending on the control target, it is best to use multi-core cables appropriate for each control target. Both CPEV and CPEE cables are often used for such control signal transmission.

CPEV: Pair-type polyethylene insulated vinyl sheathed local cable

CPEE: Pair-type polyethylene insulated polyethylene sheathed local cable

Table 9-3. CPEV and CPEE cable characteristics

Performance Characteristic	CPEV	CPEE
Chemical resistance	Excellent	Excellent
Heat resistance	Good	Excellent
Flame resistance	Good	Poor
Weather resistance	Good	Excellent
Water resistance	Good	Excellent
Flexibility	Good	Good
Connection ease	Good	Normal

**1) Short-distance control**

A “direct control” system draws power directly from the remotely controlled unit. Over longer distances, however, drops in voltage will gradually make such control impossible.

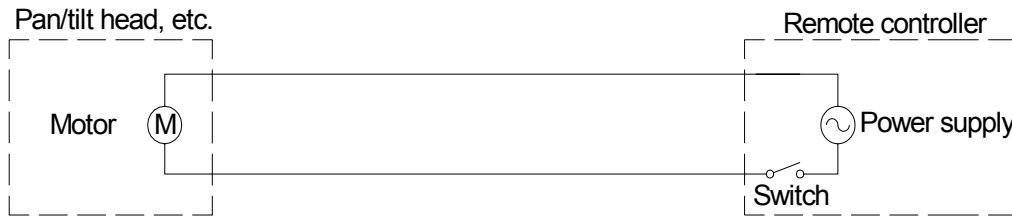

Figure 9-3. Direct Control System

**2) Long-distance control**

A “relay control” system performs control from a remote control unit via a relay box.

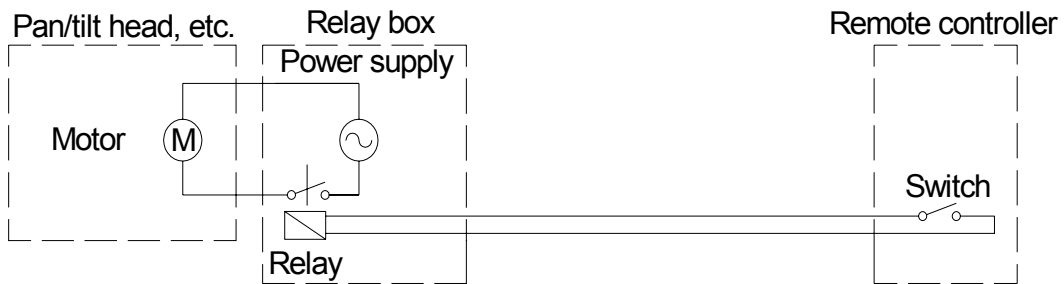

Figure 9-4. Relay Control System

Maximum cable lengths will differ depending on the type of pan/tilt head used, but approximate lengths are as shown in Table 9-4.

Table 9-4. Remote Control vs. Maximum Cable Length (Example)

		Maximum Cable Distance (m)				
Cable diameter (mm)		Ø0.5	Ø0.65	Ø0.9	Ø1.2	Ø1.6
Direct control system	Outdoor application	-	-	45	80	140
	Indoor application	-	-	20	35	60
Relay control system	Outdoor application	600	1000	1300	2300	-
	Indoor application	500	800	1300	2300	-

Table 9-5 shows remote control targets.

Table 9-5. Remote Control Targets

Equipment	Control targets
Pan/tilt head	Up
	Down
	Right
	Left
	Auto-pan
Zoom lens	Telescope
	Wide angle
	Far
	Near
	Bright
Housing	Dark
	Heater and fan
	Wiper
Camera	Defroster
	Power supply

### 3) RS-485 systems

RS-485 systems control the camera, zoom lens and/or housing using communications based on the RS-485 standard. As shown in Figure 9-5, a pair of twisted-pair cables is used as the control cable between a Combination Dome Camera and the Remote Controller, facilitating cable installation.

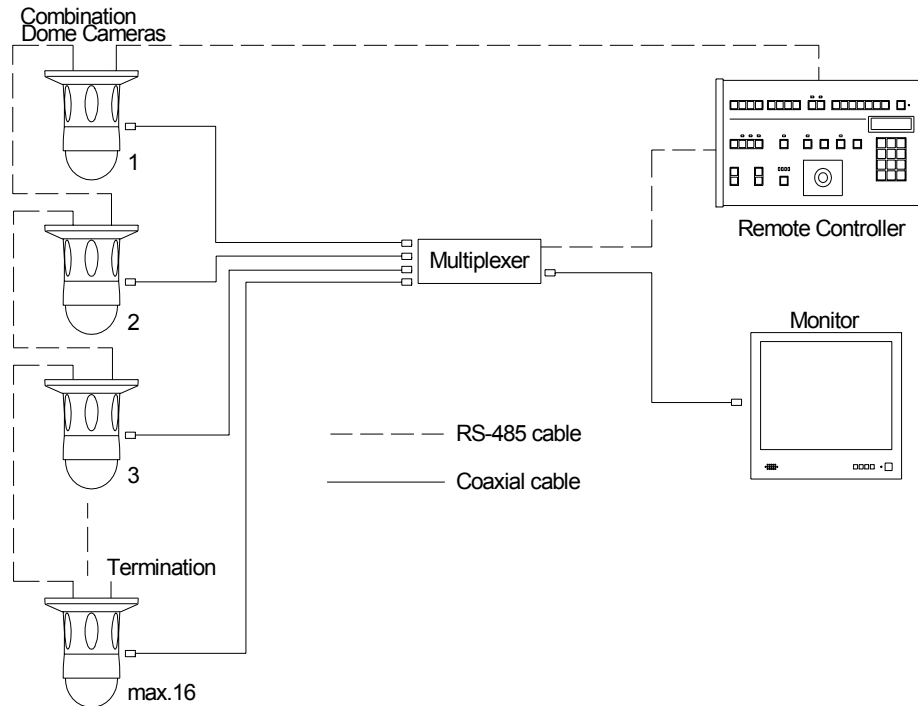

Figure 9-5. RS-485 Systems

#### 9-4. Electrical power construction requirements

Be sure to confirm the voltage and power capacity when specifying the electrical power supply requirements. Note that the voltage of commercially supplied power may fluctuate in some cases. Further, since a large surge of electric current generally flows when the power to monitors is turned on, special care needs to be taken to ensure proper power capacity. For systems using a large number of monitors, a circuit breaker capacity of three times the rated power consumption is recommended, as is the use of an electrical power distributor with a built-in delay circuit that supplies power to each monitor one after another instead of all at once.

## 10. Making Drawings

### 10-1. Preparing block diagrams

Once the basic needs and components of a system have been determined, the next process is to reflect these in a block diagram. Points to bear in mind when creating a block diagram are described below.

#### 1) Organize equipment by installation location.

To make a block diagram as clear and easy to understand as possible, place pieces of equipment that will exist in the same location as close to one another as possible and enclose them using a dashed line.

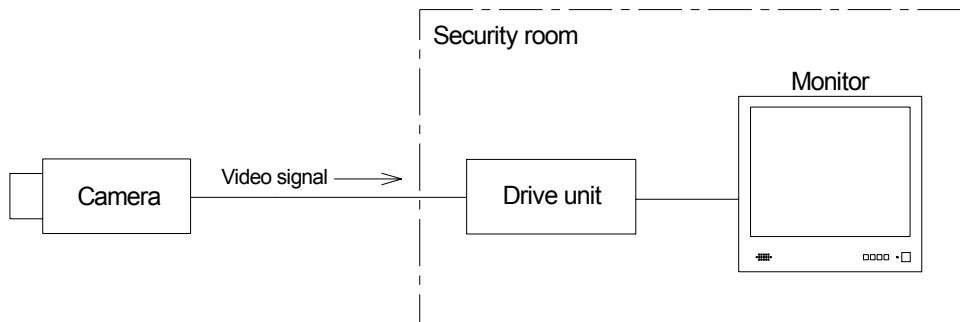

Fig. 10-1. Block diagram for equipment installed in the same location

#### 2) Create the drawing so that the signal flow moves from left to right and from top to bottom.

Cameras and microphones should generally be placed on the left-hand side. Show outputs using lines extending from the right of or below connected equipment and show inputs using lines to the left of or above the equipment. If this makes the diagram difficult to read, try using arrows instead of lines to indicate signal flow.

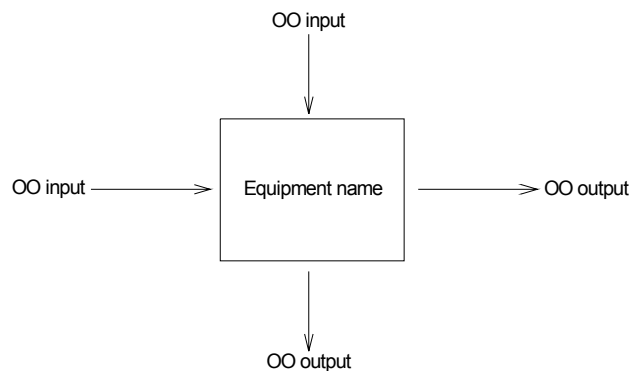

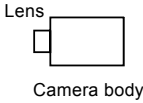
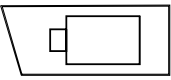
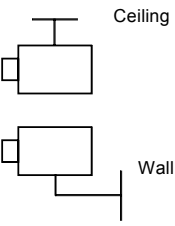
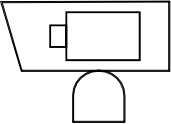

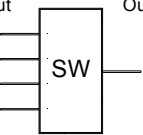



Fig. 10-2. method of the signal flow

**3) Make the block diagram as detailed as possible.**

Drawing a block diagram clarifies the signal flow and helps you to identify errors in your design. Try to draw the block diagram to include details such as the confirmed input and output specifications for each piece of equipment.

**10-2. CCTV drawing symbols**

Table 10-1. CCTV Drawing Symbols (Examples)

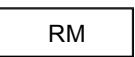
Name	Symbol	Description
TV camera		Used on block diagrams and layout diagram. The lens side is to the left.
Camera protection case		The window side is to the left
TV camera direct mounting method		Ceiling suspension Wall mounting
Motorized pan/tilt head		Erect mounting type Ceiling suspension type
Signal equipment	 <p>Place an applicable symbol within the rectangular.</p>	VDA: Video distribution amplifier PDA: Pulse distribution amplifier SG: Sync signal generator
Switcher		The figure here shows a switcher with a 4-IN/1-OUT configuration.
Monitor		
VCR		
DVR		
Operation device		

## Appendix Unit Conversion Table

Meter	Inch	Foot	Yard	Mile
1	39.3707	3.28089	1.09363	0.000621
0.025399	1	0.08333	0.027777	0.000015
0.304794	12	1	0.333333	0.000189
0.914383	36	3	1	0.000568
1,609.31	63,360	5,280	1,760	1



Closed Circuit Television Systems  
Fundamentals Course

TOA Corporation. TTI

04/01/2005

Edited 06/20/2005