



OPERATING INSTRUCTIONS

SPEAKER SYSTEMS

HS-1200BT
HS-1200WT
HS-1500BT
HS-1500WT

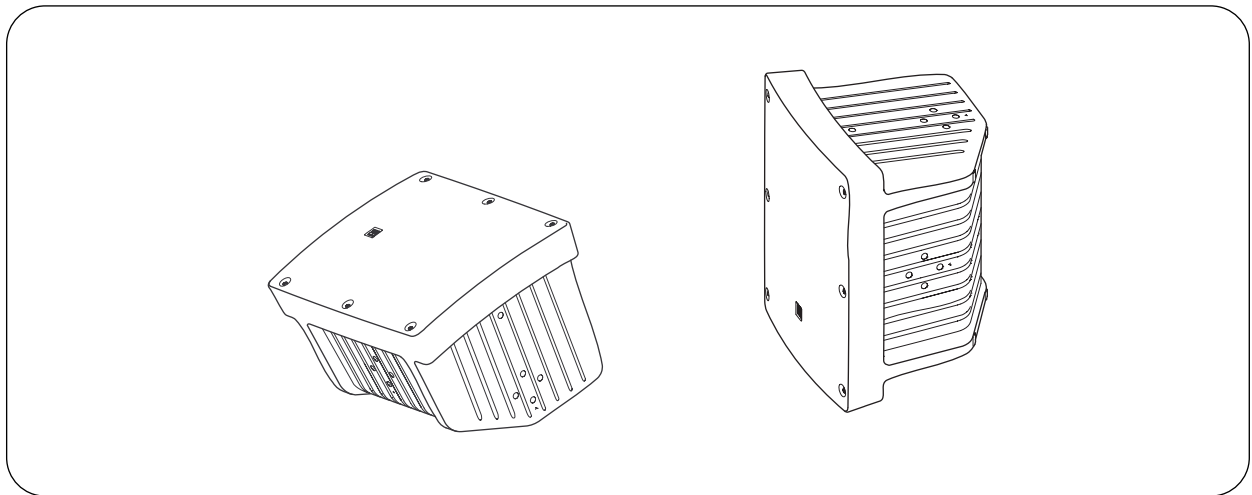

TABLE OF CONTENTS

1. SAFETY PRECAUTIONS	2	8. INSTALLATION	5
2. GENERAL DESCRIPTION	3	9. EQUALIZING BY THE	
3. FEATURES	3	DIGITAL SIGNAL PROCESSOR	7
4. DIMENSIONAL DIAGRAM	3	10. SPECIFICATIONS	8
5. INPUT TERMINAL SECTION	4	Accessories	8
6. IMPEDANCE CHANGE	4	Optional products	8
7. ABOUT THE INPUT OVERLOAD			
PROTECTION CIRCUIT	4		

Thank you for purchasing TOA's Speaker System.
Please carefully follow the instructions in this manual to ensure long, trouble-free use of your equipment.

1. SAFETY PRECAUTIONS

- Before installation or use, be sure to carefully read all the instructions in this section for correct and safe operation.
- Be sure to follow all the precautionary instructions in this section, which contain important warnings and/or cautions regarding safety.
- After reading, keep this manual handy for future reference.

Safety Symbol and Message Conventions

Safety symbols and messages described below are used in this manual to prevent bodily injury and property damage which could result from mishandling. Before operating your product, read this manual first and understand the safety symbols and messages so you are thoroughly aware of the potential safety hazards.



WARNING

Indicates a potentially hazardous situation which, if mishandled, could result in death or serious personal injury.

When Installing the Unit

- Avoid installing or mounting the unit in unstable locations, such as on a rickety table or a slanted surface. Doing so may result in the unit falling down and causing personal injury and/or property damage.
- Install the unit only in a location that can structurally support the weight of the unit and the mounting bracket. Doing otherwise may result in the unit falling down and causing personal injury and/or property damage.
- Since the unit is designed for in-door use, do not install it outdoors. If installed outdoors, the aging of parts causes the unit to fall off, resulting in personal injury. Also, when it gets wet with rain, there is a danger of electric shock.
- Owing to the unit's size and weight, be sure that at least two persons are available to install the unit. Failure to do so could result in personal injury.
- Do not use other methods than specified to mount the bracket. Extreme force is applied to the unit and the unit could fall off, possibly resulting in personal injuries.
- Use screws that are appropriate for the ceiling's or wall's structure and composition. Failure to do so may cause the unit to fall, resulting in personal injury.
- Ensure that all screws are securely tightened. If they are not tightened or firmly secured after installation, the unit could fall down, possibly resulting in personal injury.
- Use the specified mounting bracket in combination. Doing otherwise may cause the unit or component to fall off, resulting in personal injury.
- Do not mount the unit in locations exposed to constant vibration. The mounting bracket can be damaged by excessive vibration, potentially causing the unit to fall, which could result in personal injury.



CAUTION

Indicates a potentially hazardous situation which, if mishandled, could result in moderate or minor personal injury, and/or property damage.

When Installing the Unit

- When unpacking or installing the unit, be sure to handle it with two or more persons. Falling or dropping the unit may cause personal injury.
- Avoid touching the unit's sharp metal edge to prevent injury.
- To avoid electric shocks, be sure to switch off the amplifier's power when connecting speakers.



CAUTION

Indicates a potentially hazardous situation which, if mishandled, could result in moderate or minor personal injury, and/or property damage.

When the Unit is in Use

- Do not place heavy objects on the unit as this may cause it to fall or break which may result in personal injury and/or property damage. In addition, the object itself may fall off and cause injury and/or damage.
- Make sure that the volume control is set to minimum position before power is switched on. Loud noise produced at high volume when power is switched on can impair hearing.
- Do not operate the unit for an extended period of time with the sound distorting. This is an indication of a malfunction, which in turn can cause heat to generate and result in a fire.

2. GENERAL DESCRIPTION

TOA's HS-1200 series and HS-1500 series speakers are 2-way speaker systems made of resin, and feature a large diameter woofer. They can be installed in many different applications with combined use of the supplied handles and the optional mounting brackets.

3. FEATURES

- Tweeter array realizes a 90° horizontal x 40° vertical directivity control at high frequencies
- Compact and lightweight with its high frequency tweeter array arranged in front of the low frequency woofer
- Built-in overload protection circuitry for the tweeters
- Both permanent and temporary installations available
- Either vertical or horizontal speaker installation available for the permanent installation
- Easy to carry with a handy handle
- Both high- and low-impedance applications available by a rotary switch

4. DIMENSIONAL DIAGRAM

[Front]

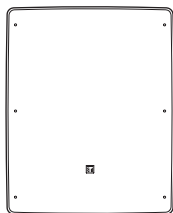

[Side]

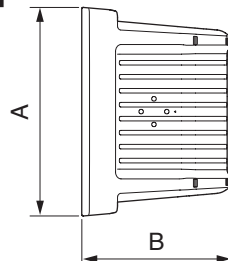

[Rear]

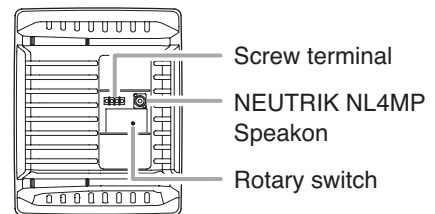

[Bottom]

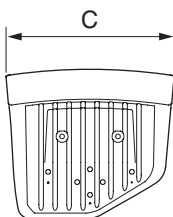

Model	Dimensions		
	A	B	C
HS-1200BT/1200WT	448 (17.64)	320 (12.6)	361 (14.21)
HS-1500BT/1500WT	560 (22.05)	400 (15.75)	451 (17.76)

Unit: mm (inches)

5. INPUT TERMINAL SECTION

- As the Speakon connector is internally connected in parallel to the screw terminal as shown below, you can use either of the two.
- The usable connector (on the cable end) that matches the NEUTRIK NL4MP Speakon is NEUTRIK NL4FX Speakon.
- Input terminal connection diagram is as shown below.

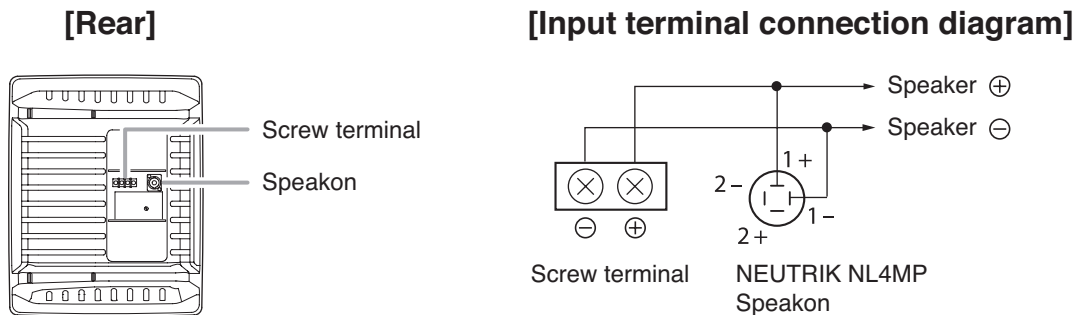

6. IMPEDANCE CHANGE

To change the impedance, use a standard screwdriver to rotate the rotary switch on the speaker's rear panel to select the desired input power.

This switch is factory-preset to 670 Ω.

Note

When using a high-impedance amplifier, never select 8 Ω, as this will damage the speaker and the amplifier. Be sure to turn the rotary switch to 8 Ω when using a low-impedance amplifier.

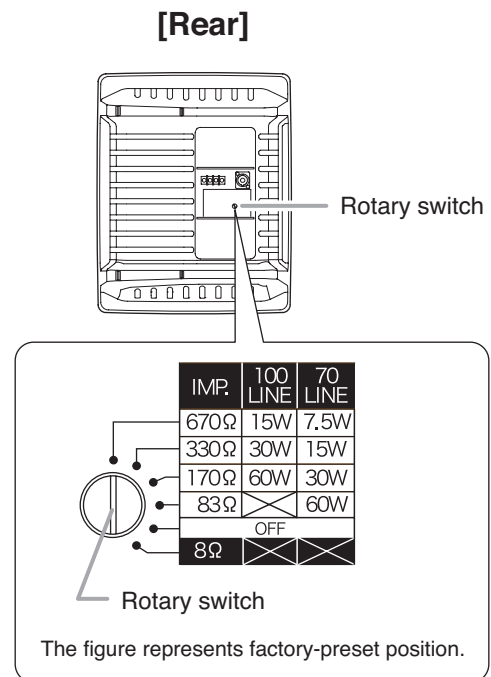

7. ABOUT THE INPUT OVERLOAD PROTECTION CIRCUIT

The speaker system has a built-in input overload protection circuitry. If an excessive input signal is applied to the speaker, the protection circuitry is activated and cuts off the signal input to the tweeters. A sudden drop of the sound volume level during speaker operation indicates that the protection circuitry has been activated. In such a case, reduce the amplifier volume and wait. The protection circuitry is automatically reset after approximately 10 seconds. After the circuitry is reset, set the volume at a lower level than before.

Note

This input overload protection circuitry does not completely protect the speaker component. Depending on the nature of the excessive input signal applied to the speaker, there may be damage to the speaker components before protection circuitry can operate. Also, if the excessive input signal is applied to the speaker for extended periods of time, the protection circuitry may be damaged and will not recover. Take special care that the excessive input signal is not applied to the speaker during use.

8. INSTALLATION

8.1. Installing to a Ceiling or Wall

Install the speaker system to a ceiling or wall using the optional mounting brackets shown below.

Note

Refer to the instruction manual enclosed with the HY-1200 series or HY-1500 series Mounting Bracket for its mounting details.

8.1.1. HY-1200VB, HY-1200VW, HY-1500VB and HY-1500VW Mounting Brackets (For vertical speaker mounting)

- These brackets are designed to mount HS series speakers to ceilings or walls vertically.
HY-1200VB and HY-1200VW: For the HS-1200 series speaker system
HY-1500VB and HY-1500VW: For the HS-1500 series speaker system
- They allow speaker's vertical angle to be adjusted. (Ceiling: From 15° upward to 90° downward, Wall: From 15° upward to 60° downward)

Note: They also permit speaker's horizontal angle to be adjusted in conjunction with the optional HY-C0801 or HY-C0801W Ceiling Mount Bracket, or the HY-W0801 or HY-W0801W Wall Mount Bracket.

[Ceiling installation]

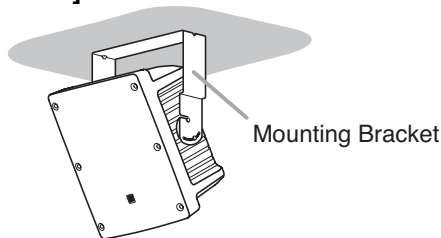

[Wall installation]

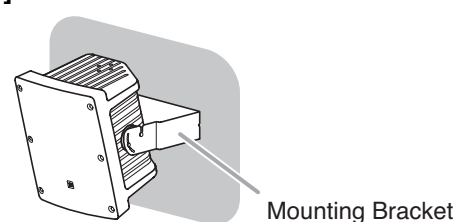

8.1.2. HY-1200HB, HY-1200HW, HY-1500HB and HY-1500HW Mounting Brackets (For horizontal speaker mounting)

- These brackets are designed to mount HS series speakers to ceilings or walls horizontally.
HY-1200HB and HY-1200HW: For the HS-1200 series speaker system
HY-1500HB and HY-1500HW: For the HS-1500 series speaker system
- They allow speaker's vertical angle to be adjusted. (Ceiling: From 0° horizontal to 90° downward, Wall: From 15° upward to 60° downward)

Note: They also permit speaker's horizontal angle to be adjusted in conjunction with the optional HY-C0801 or HY-C0801W Ceiling Mount Bracket, or the HY-W0801 or HY-W0801W Wall Mount Bracket.

[Ceiling installation]

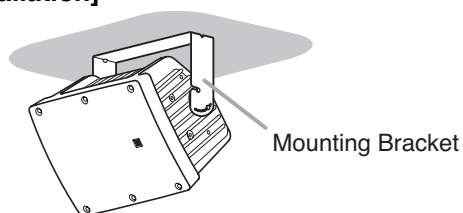

[Wall installation]

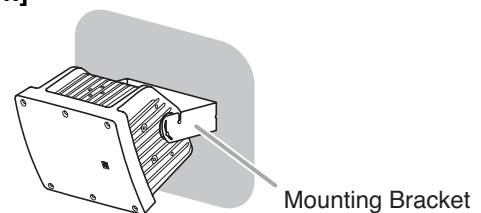

8.1.3. HY-C0801 and HY-C0801W Ceiling Mount Brackets (For ceiling installation, horizontal angle adjustable)

Installing the HS series speaker to a ceiling in conjunction with the HY-1200 series or HY-1500 series Mounting Bracket permits the speaker's horizontal angle to be adjusted.

The figure at right shows an example of vertical speaker installation.

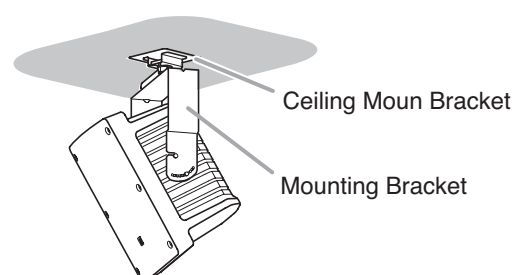

8.1.4. HY-W0801 and HY-W0801W Wall Mount Brackets (For wall installation, horizontal angle adjustable)

Installing the HS series speaker to a wall in conjunction with the HY-1200 series or HY-1500 series Mounting Bracket permits the speaker's horizontal angle to be adjusted.

The figure at right shows an example of vertical speaker installation.

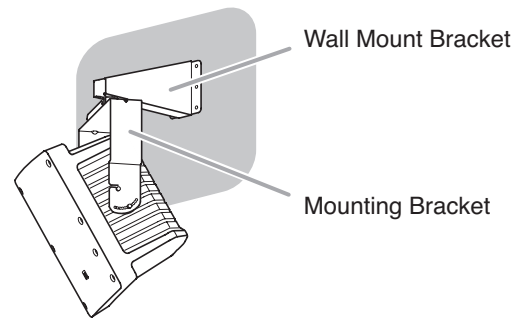

8.1.5. Safety wire installation (For speaker fall prevention)

When mounting the speaker system to the ceiling or wall, install a safety wire as needed.

WARNING

When installing the safety wire, be sure to follow the instructions below. Failure to do so may cause the speaker to fall off, resulting in personal injury.

- Use a wire rope of 2 mm (0.08") or more in diameter. (The safety wire is not supplied.)
- Tighten the safety wire to take up the slack. Otherwise, impact shock at speaker fall may cause the wire-connected parts or wire itself to break.
- Install the safety wire to a place that can structurally support the full weight of load.
- Screw a speaker suspension bolt (M8) into one of the screw holes on the speaker's bottom surface. Then, connect the safety wire to the bolt.

Installation position of an M8 bolt
M8 (Screw pitch: 1.25 mm, effective depth: 24 mm)
Note: Unified inch screws cannot be used.

Speaker's bottom surface

Changing the orientation of the front panel logo

Turn the logo mark while holding its edges to change its orientation.

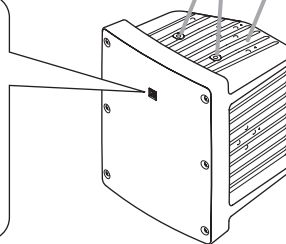
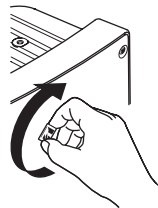

8.2. Mounting on the ST-33B Speaker Stand (optional)

Note

Refer to the instruction manual enclosed with the Speaker Stand for its mounting details.

Step 1. Fix the bracket supplied with the speaker stand to the speaker.

Step 2. Spread the tripod legs of the stand to their full extension.

Note

Spread the tripod legs until the stays extend horizontally.

Step 3. Mount the speaker with the bracket fixed onto the stand.

Step 4. Determine the speaker direction, and tighten the bracket fixing screw.

Step 5. Adjust the stand height.

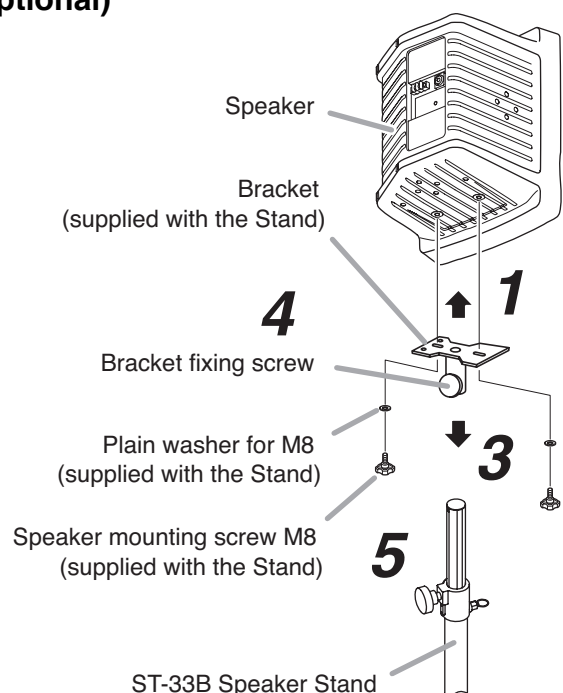

8.3. Using as a Floor Monitor

Notes

- When installing the speaker system on slippery floor, put a non-slip mat under the speaker.
- Do not kick or stand on the speaker system, as this will damage the speaker.

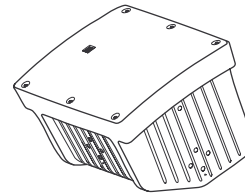

The figure shows the HS-1200 series.

8.4. Attaching the Supplied Rubber Feet

Attach the rubber feet in the case of speaker storage or on-floor speaker installation.

Note

The rubber foot has a direction (back and forth). Align the datum line on the rubber foot with the positioning mark (Δ) on the speaker unit as shown at right.

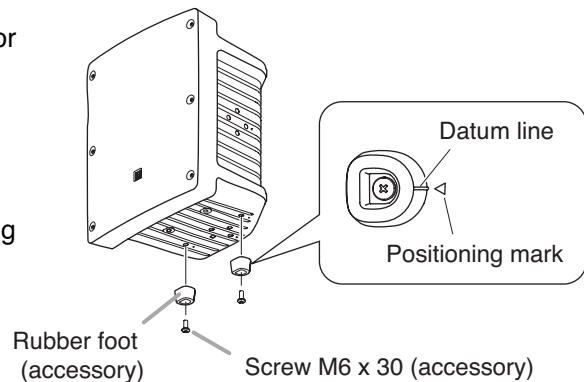

8.5. Attaching a Handle

The speaker system comes with a handy carrying handle. Attach the handle on the speaker's top surface.

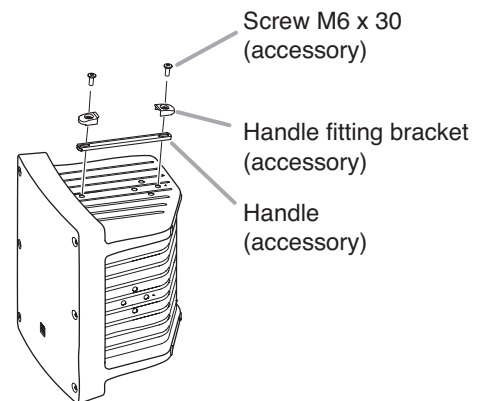

9. EQUALIZING BY THE DIGITAL SIGNAL PROCESSOR

The speaker system is capable of providing high-efficiency and wide range reproduction without using an equalizer, however more clear and dynamic sound quality can be reproduced by using our digital signal processor and performing its settings as shown in the tables below.

[For the HS-1200BT and HS-1200WT]

Filter	Frequency (Hz)	Gain (dB)	Q
HPF (12 dB)	50	—	1.432
PEQ	520	-4.0	1.414
PEQ	1600	-2.0	5.764
PEQ	2300	-4.0	5.764
PEQ	5000	-2.0	1.011
PEQ	14000	+3.0	1.204

[For the HS-1500BT and HS-1500WT]

Filter	Frequency (Hz)	Gain (dB)	Q
HPF (12 dB)	50	—	1.274
PEQ	530	-3.5	2.145
PEQ	1300	-3.0	2.871
PEQ	2500	-3.0	2.871
PEQ	4500	-3.5	1.011
PEQ	14000	+1.5	0.718

10. SPECIFICATIONS

Model No.	HS-1200BT	HS-1200WT	HS-1500BT	HS-1500WT	
Enclosure	Sealed type				
Rated Power	Continuous pink noise: 100 W, Continuous program: 300 W				
Rated impedance	8 Ω 100 V line: 170 Ω (60 W), 330 Ω (30 W), 670 Ω (15 W) 70 V line: 83 Ω (60 W), 170 Ω (30 W), 330 Ω (15 W), 670 Ω (7.5 W)				
Sensitivity	97 dB (1 W, 1m)		98 dB (1 W, 1m)		
Frequency Response	70 to 20,000 Hz		60 to 20,000 Hz		
Crossover Frequency	3 kHz				
Directivity Angle	Horizontal: 90°, Vertical: 40°				
Speaker Component	Low frequency 30 cm (12") cone type High frequency Balanced dome tweeter x 6		Low frequency 38 cm (15") cone type High frequency balanced dome tweeter x 6		
Input Terminal	NEUTRIK NL4MP Speakon and M4 screw terminal (Barrier spacing: 9 mm)				
Finish	Enclosure	Polypropylene, black	Polypropylene, white	Polypropylene, black	Polypropylene, white
	Punched net	Surface-treated steel plate, black	Surface-treated steel plate, white	Surface-treated steel plate, black	Surface-treated steel plate, white
Operating Temperature	-10°C to +50°C (14°F to 122°F)				
Dimensions	361 (w) x 448 (h) x 320 (d) mm (14.21" x 17.64" x 12.6")		451 (w) x 560 (h) x 400 (d) mm (17.76" x 22.05" x 15.75")		
Weight	10 kg (22.05 lb)		14 kg (30.86 lb)		

Note: The design and specifications are subject to change without notice for improvement.

• Accessories

Handle	1
Handle fitting bracket	2
Rubber foot	2
Screw M6 x 30 (Used for attaching a handle and rubber foot.)	4

• Optional products

Mounting bracket (For vertical speaker mounting): HY-1200VB, HY-1200VW, HY-1500VB, HY-1500VW
 Mounting bracket (For horizontal speaker mounting): HY-1200HB, HY-1200HW, HY-1500HB, HY-1500HW
 Ceiling mount bracket: HY-C0801, HY-C0801W
 Wall mount bracket: HY-W0801, HY-W0801W
 Speaker stand: ST-33B

Traceability Information for Europe (EMC directive 2004/108/EC)

Manufacturer:
 TOA Corporation
 7-2-1, Minatojima Nakamachi, Chuo-ku, Kobe, Hyogo,
 Japan

Authorized representative:
 TOA Electronics Europe GmbH
 Suederstrasse 282, 20537 Hamburg,
 Germany