



INSTRUCTION MANUAL

DIRECT SELECT CONTROL CARD VS-900DI

DIRECT SELECT I/O CARD VS-910DI

Important

1. These cards contain CMOS IC's and may be damaged by static discharge. It is advisable to wear an earth-grounded wrist strap when handling the cards.
2. Turn off all power to the system before unplugging or plugging in connectors to the cards.

Please follow the instructions in this manual to obtain the optimum results from this unit.
We also recommend that you keep this manual handy for future reference.

TOA Corporation

TABLE OF CONTENTS

1. GENERAL DESCRIPTION	4
2. SYSTEM CONFIGURATION AND OPERATION	
2.1. System Configuration	4
2.2. Basic Operation	5
3. NOMENCLATURE AND DIMENSIONAL DIAGRAM	
Direct Select Control Card VS-900DI	6
Direct Select I/O Card VS-910DI	8
4. SYSTEM DESIGN	9
5. INSTALLATION	
5.1. Setting the VS-900DI Station Addresses	9
5.2. Setting the VS-910DI Card Numbers	10
5.3. Installing the VS-900DI/VS-910DI	10
5.4. VS-900DI Connection	
5.4.1. Connector connection	11
5.4.2. CN2 power supply terminal connection	11
5.4.3. Connection to the exchange	12
5.4.4. Connection to the MS-900 Master Station	13
5.4.5. Mounting the ferrite clamp	13
5.4.6. CN5 in-use indication output connection	14
5.4.7. CN4 Input key (C/PTT/Xfer/Test key) connection	14
5.4.8. CN8 headset connection	15
5.4.9. Earth grounded connection	15
5.4.10. CN9 microphone input connection	16
5.4.11. CN10 speaker output connection	16
5.5. VS-910DI Connection	
5.5.1. CN3 power supply terminal connection	17
5.5.2. Calling station indication output connection	17
5.5.3. Direct select input connection	18
5.5.4. External equipment control output connection	19
5.5.5. VS-910DI's CN4/CN5/CN6 connections	20
6. REGISTRATION	
6.1. Direct Select Setting	21
6.2. Direct Select Dial Setting	21
6.3. Programming PC Connection	22
6.4. Programming Data Entry	
6.4.1. Entry when the VS-900DI alone is used	22
6.4.2. Entry when the VS-900DI is connected to the VS-910DI	22

7. OPERATION TEST	
7.1. Operation Check by Means of the Test Switch	23
7.2. Check through Individual Operations	
7.2.1. Checking VS-900DI/VS-910DI for proper operation without using the master station	23
7.2.2. Checking VS-900DI/VS-910DI for proper operation when using the master station	23
8. FUNCTIONS AND OPERATION	
8.1. Calling/Called Station Indication Output	24
8.2. Direct Select Input	25
8.3. External Equipment Control Output	
8.3.1. CCTV interlock output	26
8.3.2. Remote door control output	27
8.4. Conversation Using the Master Station	28
8.5. Conversation Using the VS-900DI and Not Using the Master Station	28
9. SPECIFICATIONS	29
Accessories	29

FCC REQUIREMENTS

WARNING (For U.S.A. only)

This equipment has been tested and found to comply with the limits for a Class A digital device, pursuant to Part 15 of the FCC Rules. These limits are designed to provide reasonable protection against harmful interference when the equipment is operated in a commercial environment. This equipment generates, uses, and can radiate radio frequency energy and, if not installed and used in accordance with the instruction manual, may cause harmful interference to radio communications. Operation of this equipment in a residential area is likely to cause harmful interference in which case the user will be required to correct the interference at his own expense.

1. GENERAL DESCRIPTION

The VS-900DI Direct Select Control Card and VS-910DI Direct Select I/O Card are interface cards that connect to the VS-900 Exchange to enable calling-station indication output, direct select input, and external equipment control output functions. Because these interface cards also have a talk function, by mounting these cards in a control console in combination with a microphone or other devices, the system can be used as a substitute for the MS-900 Master Station.

It is also possible not to use the talk function. In this case, the function of these cards is limited to input and output control, and the MS-900 Master Station is used for conversation.

2. SYSTEM CONFIGURATION

2. 1. System Configuration

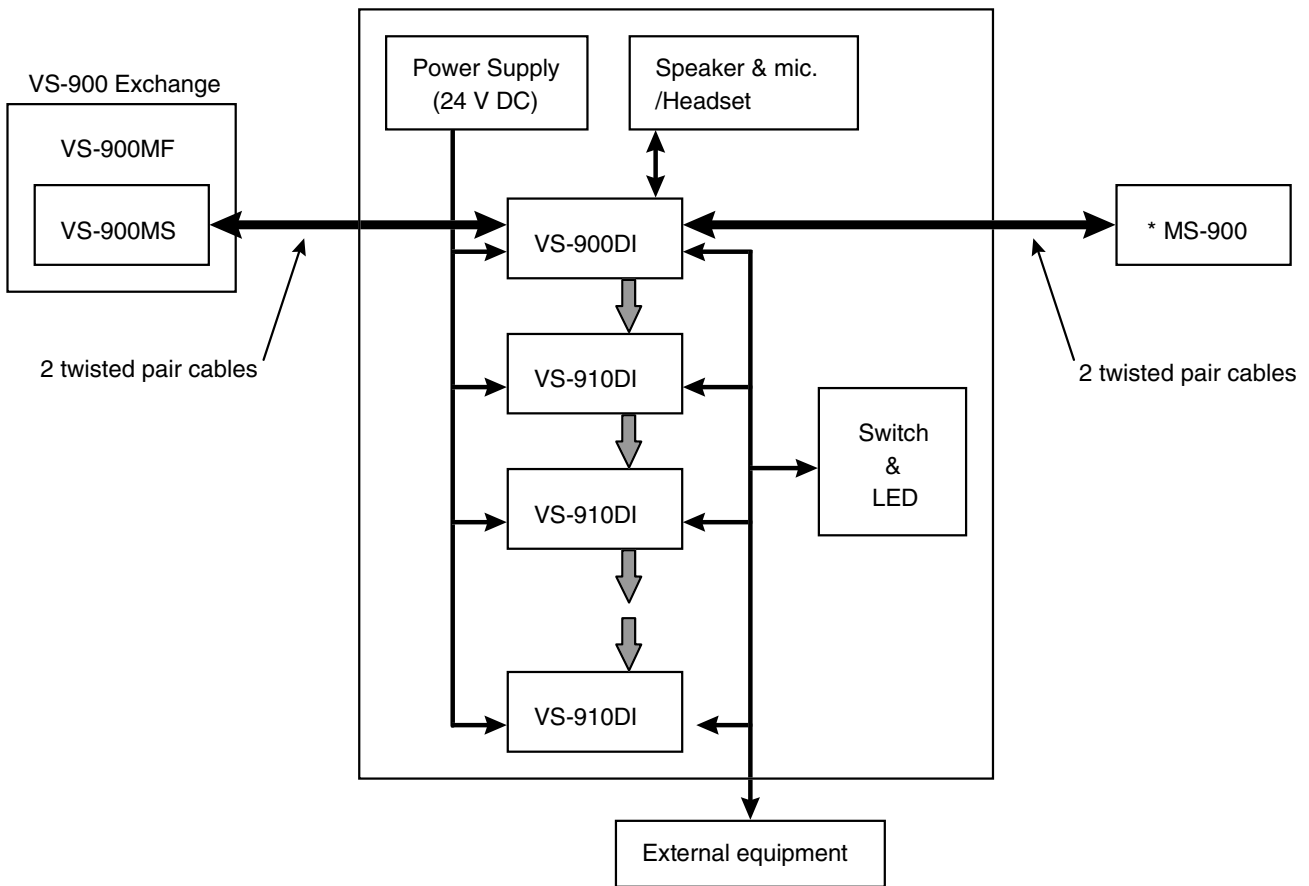

* A call can be enabled using the MS-900 Master Station.

2.2. Basic Operation

The VS-900DI Direct Select Control Card transmits, instead of the MS-900 Master Station, dial signals corresponding to key inputs. Based on information provided by the VS-900 Exchange, the VS-900DI also outputs signals for the calling station indication and external equipment control to the VS-910DI Direct Select I/O Card, which in turn controls LEDs, switches and external equipment.

Block Diagram

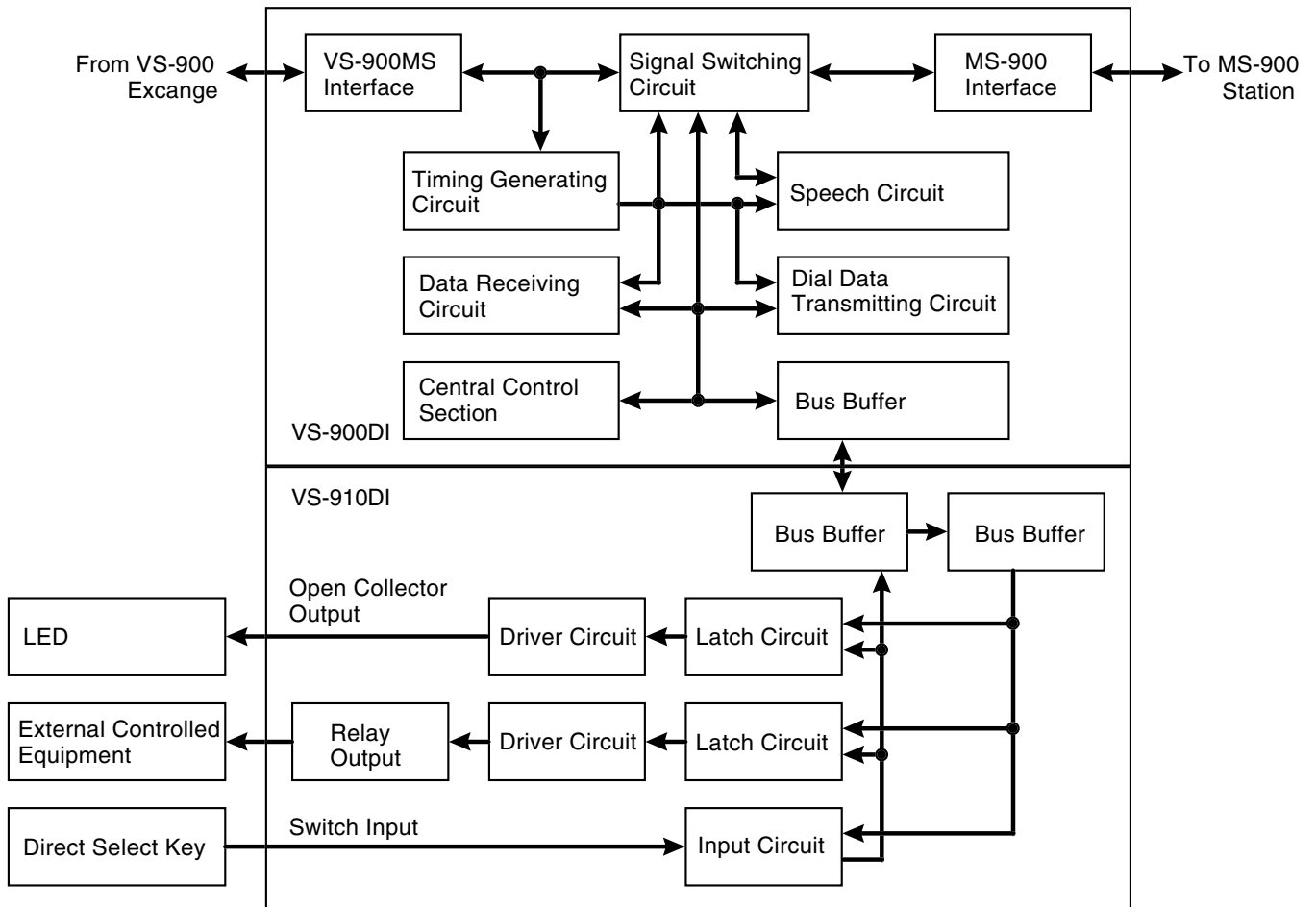

Note

For the functions of the LED drive output, relay output, and switch input, refer to p. 24 "FUNCTIONS AND OPERATION."

3. NOMENCLATURE AND DIMENSIONAL DIAGRAM

[Direct select control card VS-900DI]

Unit: mm

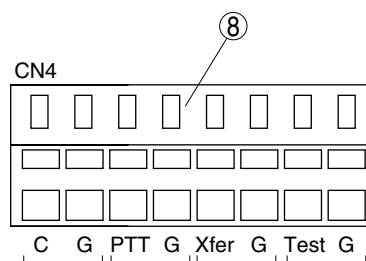
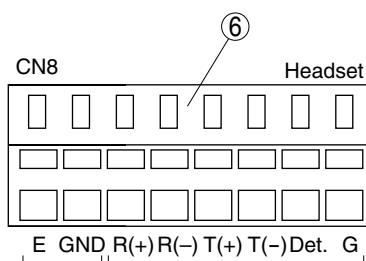
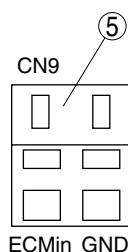
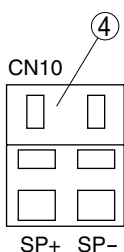
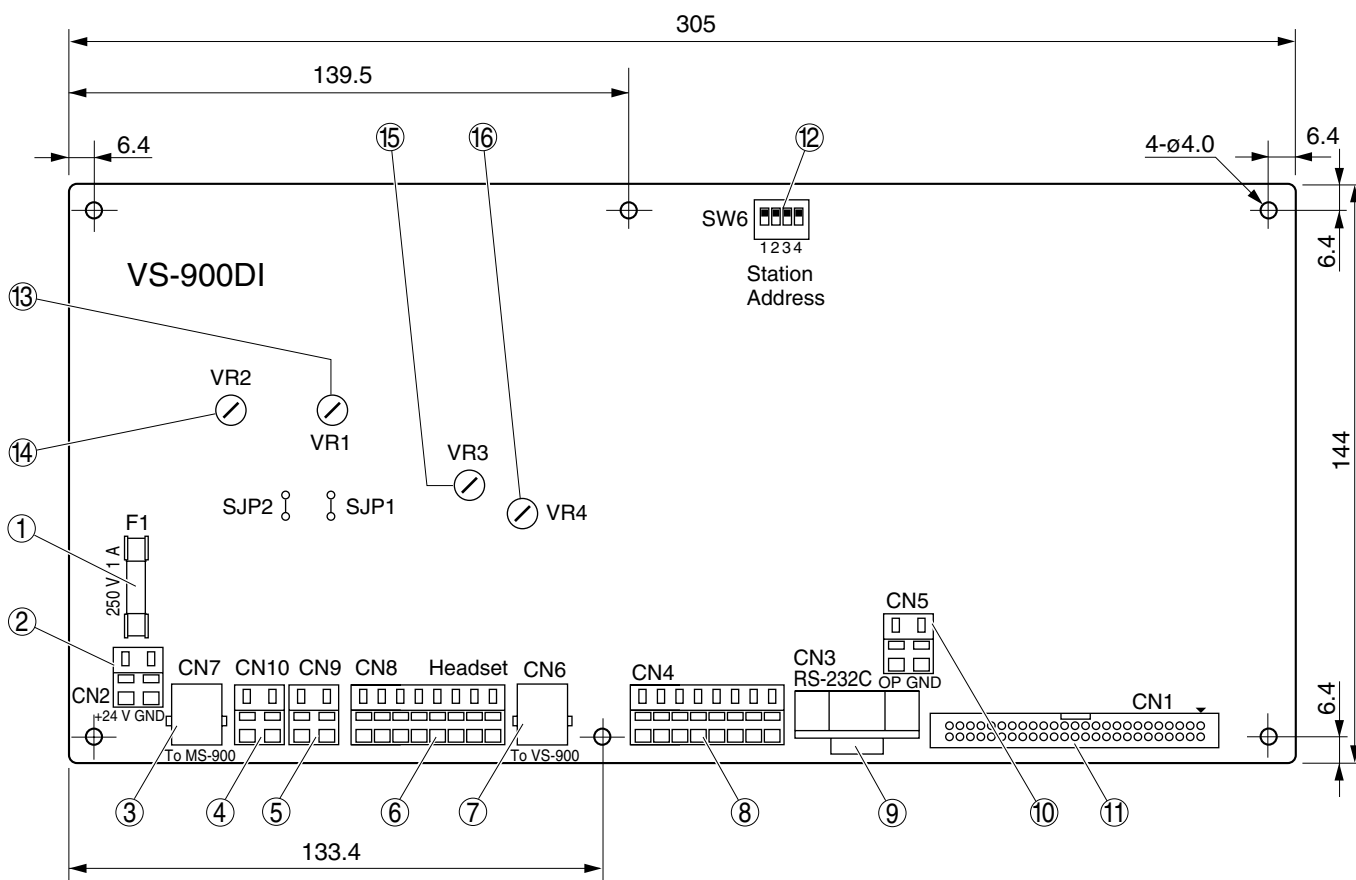

1. Fuse (250 V, 1 A) [F1]

Protects the equipment from major electrical damage.

2. 24 V DC power supply terminal [CN2]

Connects to the power supply for internal circuit operation.

3. Modular jack for MS-900 [CN7]

Connects to the master station.

4. Speaker output terminal [CN10]

Connects to an 8Ω external speaker for voice amplification when using the speech function.

5. Electret microphone input terminal [CN9]

Connects to a hands-free microphone when using the speech function.
(Phantom power is fed to this terminal with the jumper SJP2 connected.)

6. Headset and Earth/GND terminal [CN8]

Connects to a headset when using the speech function by way of the headset. Connect Terminal E to the earth ground.

7. Modular jack for VS-900 [CN6]

Connects to the VS-900MS mounted in the VS-900 exchange.

- 8. Key input terminal [CN4]**
Connects to the keys that correspond to the master station's [C], [PTT], and [XFER] keys, and the [Test] key.
- 9. RS-232C D-sub type connector (female type) [CN3]**
Used to program data corresponding to each VS-900DI's terminal.
- 10. In-use indication output terminal [CN5]**
An open collector output that transmits "make" signals while the VS-900DI is in use.
- 11. Connector for VS-910DI card [CN1]**
Connects to the VS-910DI.
- 12. Station address setting switch [SW6]**
Sets the station address number depending on the line connecting the VS-900DI.
- 13. Headset microphone sensitivity control [VR1]**
A semi-fixed volume control used to adjust headset microphone sensitivity.
- 14. Microphone sensitivity control [VR2]**
(for the microphone connected to CN9)
A semi-fixed volume control used to adjust hands-free microphone sensitivity.
- 15. Headset speaker volume control [VR3]**
A semi-fixed volume control used to adjust headset receiver volume.
- 16. Speaker volume control [VR4]**
(for the speaker connected to CN10)
A semi-fixed volume control used to adjust hands-free speaker volume.

[Direct select I/O card VS-910DI]

Unit: mm

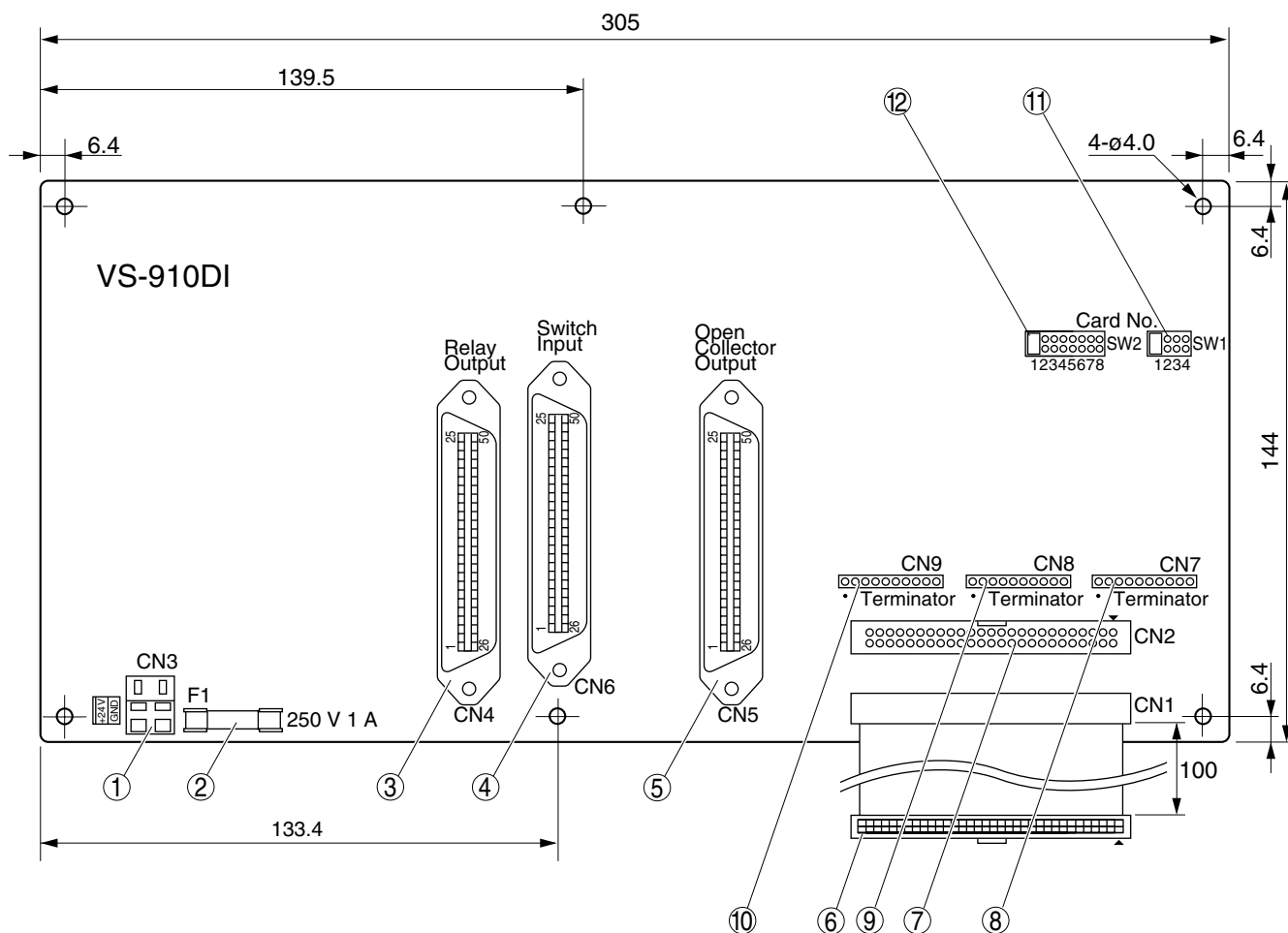

1. 24 V DC power supply terminal [CN3]

Connects to the power supply for internal circuit operation.

2. Fuse (250 V, 1 A) [F1]

Protects the equipment from major electrical damage.

3. Relay output connector ("CHAMP"® IDC connector 50P) [CN4]

Used when interlocking external equipment.

4. Switch input connector ("CHAMP"® IDC connector 50P) [CN6]

A key entry terminal for Direct Select. Pressing the key connects the call to the station programmed into that key.

5. Open collector output connector ("CHAMP"® IDC connector 50P) [CN5]

An open collector output for calling/called station indication. The indication flashes or continuously lights depending on call reception conditions.

6. Cable connector for VS-900DI or VS-910DI card [CN1]

Connects the VS-900DI or VS-910DI, and permits connection of up to 32 VS-910DI cards.

7. Connector for VS-910DI card expansion [CN2]

Connects 2 or more VS-910DI cards to the VS-900DI. Connect the second VS-910DI's cable connector (No. 6) to the first card's [CN2] connector.

8. Terminator [CN7]

9. Terminator [CN8]

10. Terminator [CN9]

Terminating resistor connectors.

When using 2 or more VS-910DI cards, remove terminator resistors of all connected VS-910DI cards except that located farthest from the VS-900DI card.

11. Card number setting switch [SW1]

12. Card number setting switch [SW2]

Sets the VS-910DI card number.

4. SYSTEM DESIGN

Prepare the required equipment according to the procedures below.

Step 1. Determine the required number of LEDs, switches, and interlocking devices.

Step 2. Determine whether or not the VS-900DI's talk function will be used.

If this card function is not used, use the MS-900 Master Station for conversation.

Step 3. Determine the number of VS-910DI cards required based on the result of Step 1 above.

Tip

The VS-910DI Direct Select I/O Card has 32 calling station indication outputs, 32 direct select inputs, and 32 external device control outputs.

Step 4. Determine the power capacity required, and prepare the power supply.

Be sure to provide sufficient power capacity for external parts such as LEDs, in addition to the current consumed by each card.







5. INSTALLATION

5.1. Setting the VS-900DI Station Addresses

Settings are required for both the station address and whether or not the talk function will be used. If the talk function is not used, use the MS-900 for conversation. Perform the following setting using switch SW6.

Note

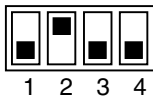
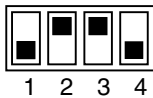
If the SW6 setting has been changed, turn OFF the unit power, then ON again.

VS-900MS	Line number	Station address	Not using the MS-900	Using the MS-900
MS/AL slot 1	1	1	ON  OFF	ON  OFF
	2	2	ON  OFF	ON  OFF
MS/AL slot 2	1	3	ON  OFF	ON  OFF
	2	4	ON  OFF	ON  OFF

5.2. Setting the VS-910DI Card Numbers

The number of the card to be used for the VS-910DI needs to be set. Perform the following setting using switches SW1 and SW2.

VS-910DI Card No.	SW1	SW2	VS-910DI Card No.	SW1	SW2	VS-910DI Card No.	SW1	SW2	VS-910DI Card No.	SW1	SW2
1			9			17			25		
2			10			18			26		
3			11			19			27		
4			12			20			28		
5			13			21			29		
6			14			22			30		
7			15			23			31		
8			16			24			32		

5.3. Installing The VS-900DI/VS-910DI

Connect each card as illustrated below.

When connecting 2 or more VS-910DI cards, remove the terminating resistors in CN7, CN8, and CN9, except the VS-910DI card farthest from the VS-900DI card.

For the interlocking outputs to the LED, switch, or external equipment, connect them after completing all connections as shown below.

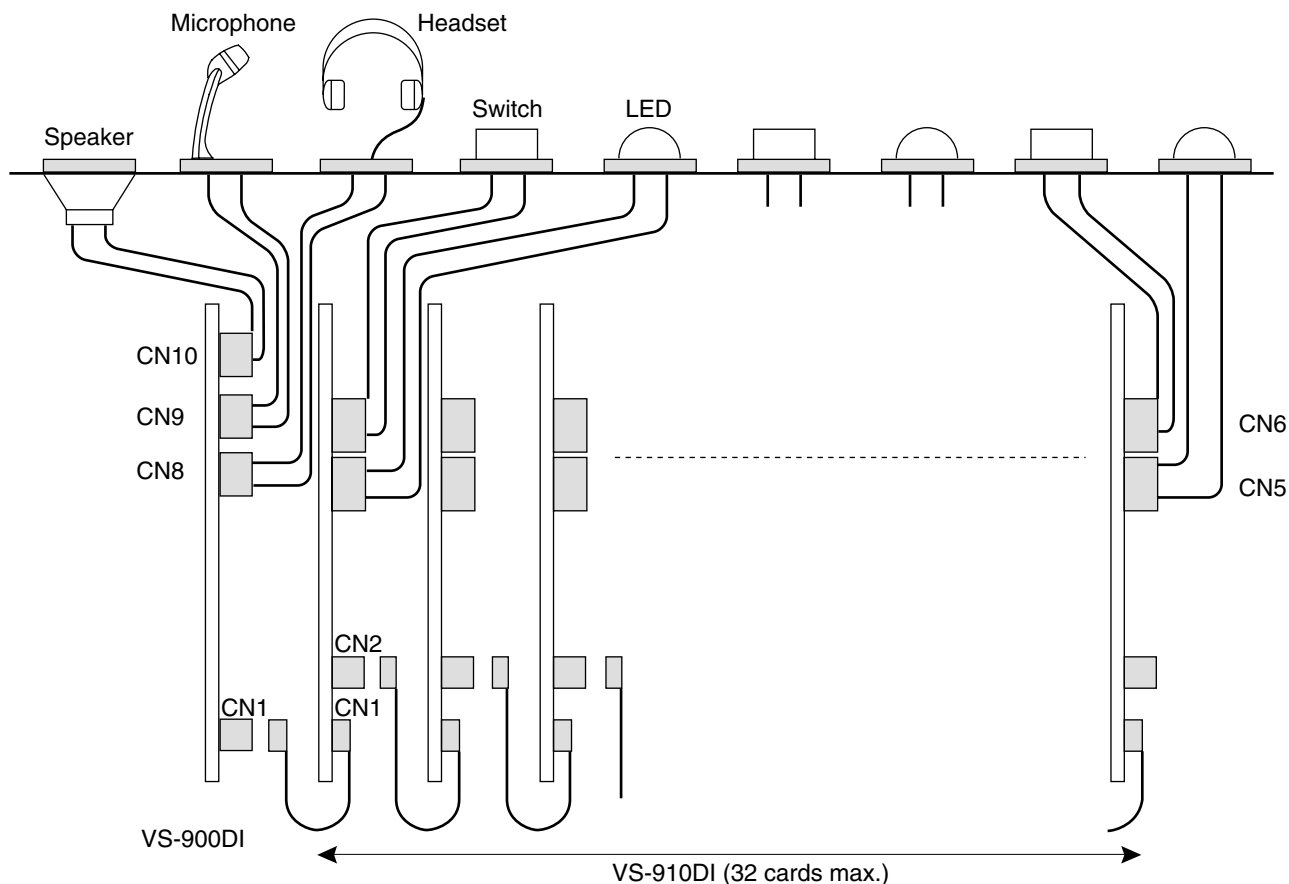

5.4. VS-900DI Connection

5.4.1. Connector connection

Step 1. Strip the end of the cable back approximately 5 mm.

Step 2. While pressing on the upper side of the connector with a standard screwdriver as shown in the figure, insert the cable leads.

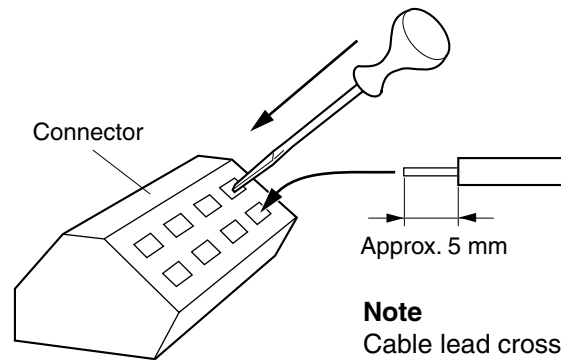

5.4.2. CN2 power supply terminal connection

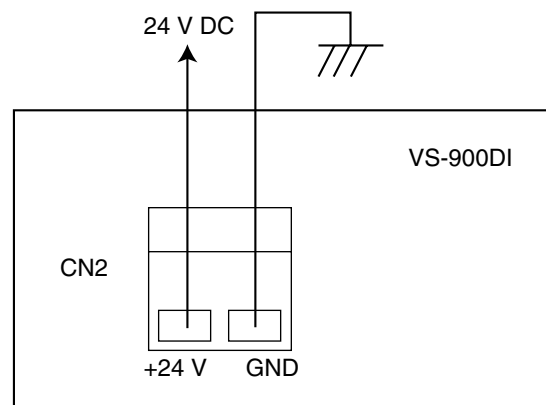

5.4.3. Connection to the exchange

- Connect the VS-900DI to the VS-900MS using 2 twisted pair cables as shown below referring to the following procedures.
 1. Fit the 4P connector (supplied with the VS-900MS) to one cable end, and a 6-position 4-contact modular jack (prepare locally) to the other cable end.
 2. Connect the modular jack to the VS-900DI's CN6 modular jack using the modular cord (supplied with the VS-900DI).
- The table below shows the maximum cable distance.

Cable type	AWG24 (0.52 mm)	AWG22 (0.65 mm)	AWG20 (0.82 mm)
Distance	0.9 km	1.5 km	2.3 km

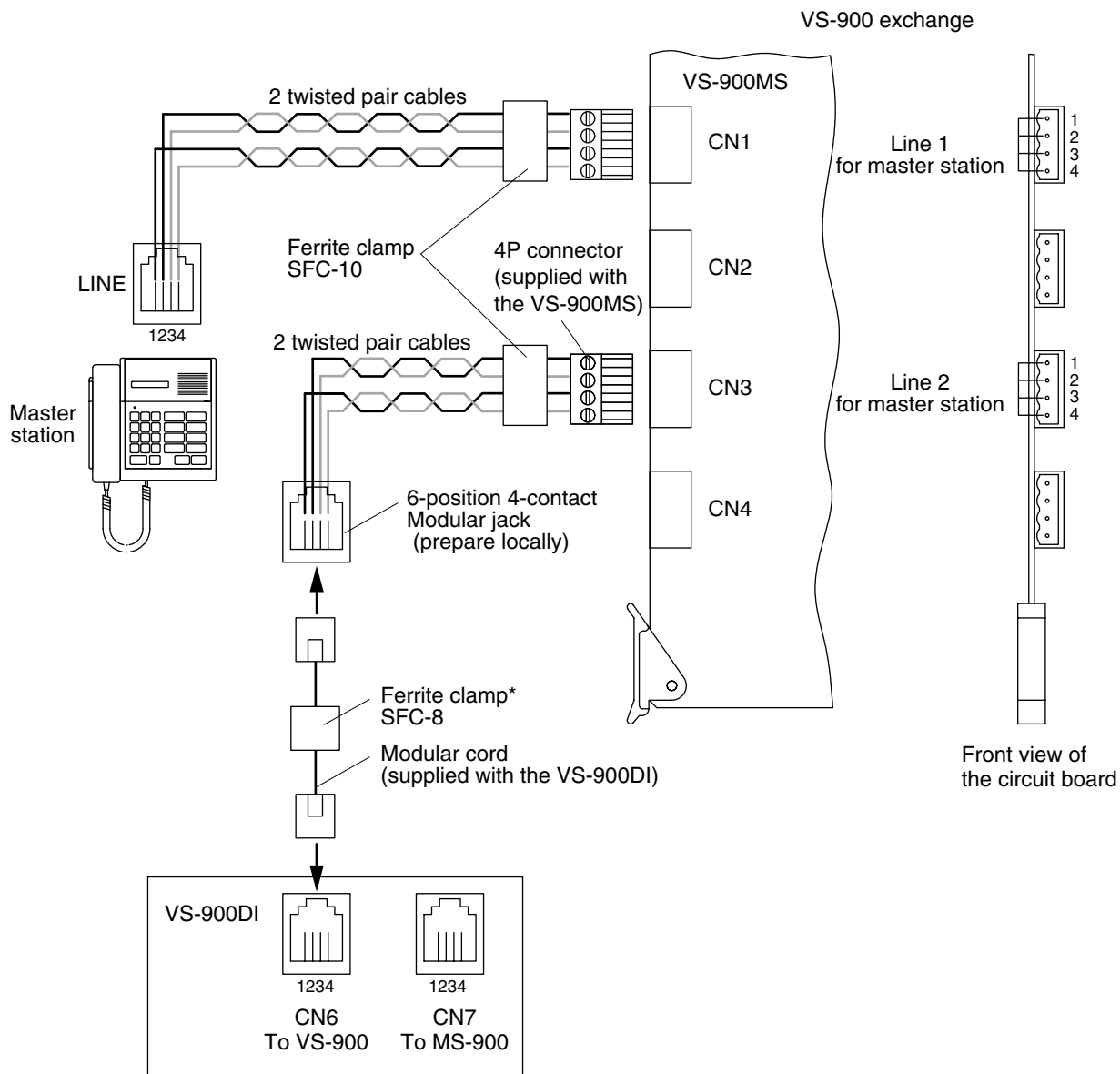

* See p.13 "Mounting the ferrite clamp."

5.4.4. Connection to the MS-900 Master Station

- Connect the VS-900DI to the MS-900 using 2 twisted pair cables as shown below referring to the following procedures.
 1. Fit a 6-position 4-contact modular jack (prepare locally) to each cable end.
 2. Connect one modular jack to the VS-900DI's CN7 modular jack using the modular cord (prepare locally), and another jack to the MS-900 modular jack using a modular cable (supplied with the MS-900).
- When using the Master Station, the maximum cable distance is the total connected distance from the exchange to the Master Station via the VS-900DI.

Cable type	AWG24 (0.52 mm)	AWG22 (0.65 mm)	AWG20 (0.82 mm)
Distance	0.9 km	1.5 km	2.3 km

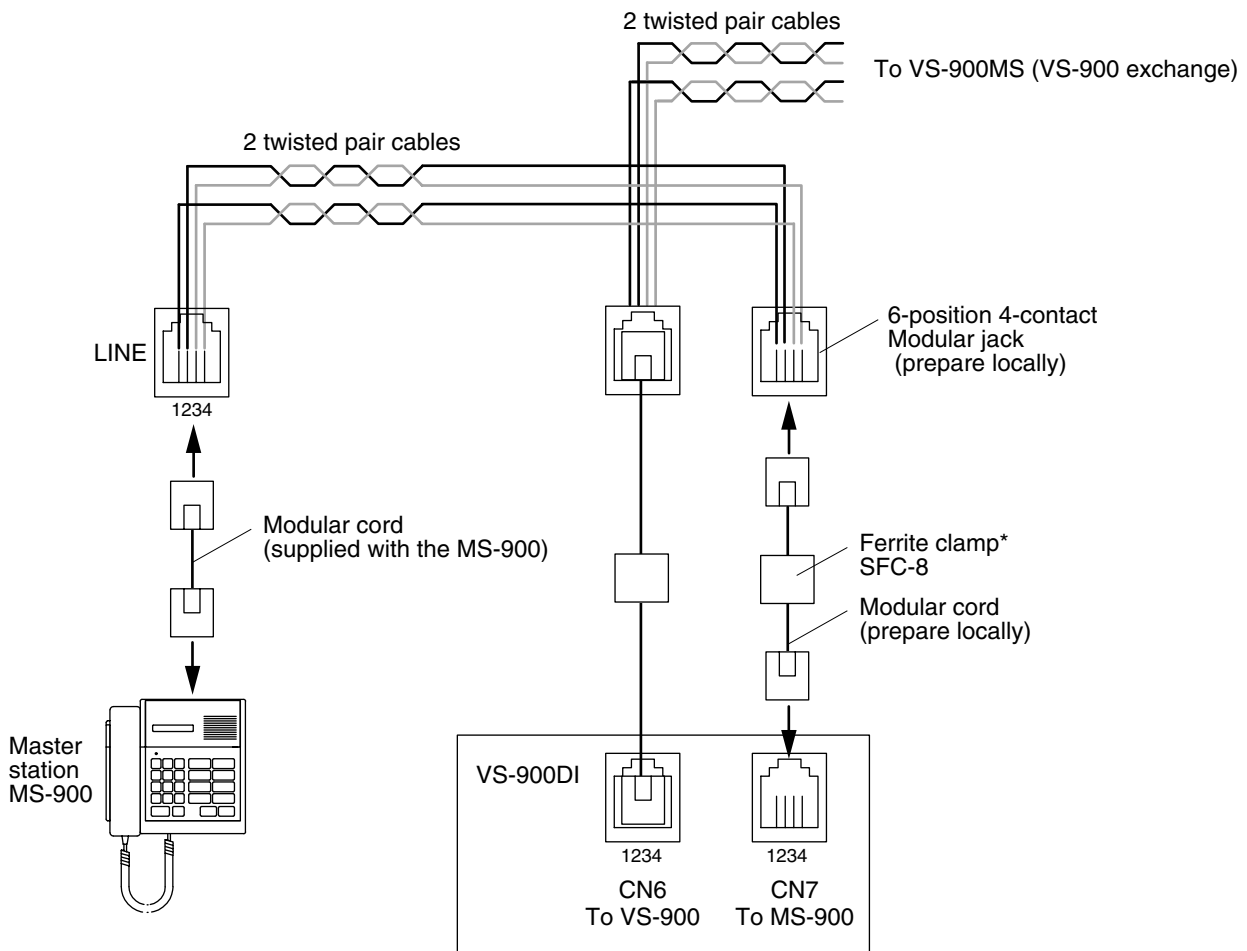

* See "Mounting the ferrite clamp" below.

5.4.5. Mounting the ferrite clamp

Mount the ferrite clamp (supplied with the VS-900DI card) on the cable in a way that the cable is looped one turn as illustrated. (This countermeasure is for complying with the CE marking and FCC requirements.)

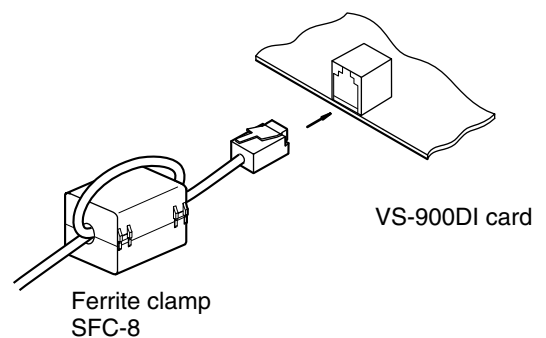

5.4.6. CN5 in-use indication output connection

- Connect the in-use indication output to the LED from the CN5 connector as shown below.
- A current capacity of 24 V DC/100 mA is required per output.
- To use an LED, connect a current limiting resistor in series with it as the resistor is not build in the card.
- Determine the appropriate resistor value depending on the amount of current (I) necessary for indication elements (LED, etc.) to be used.

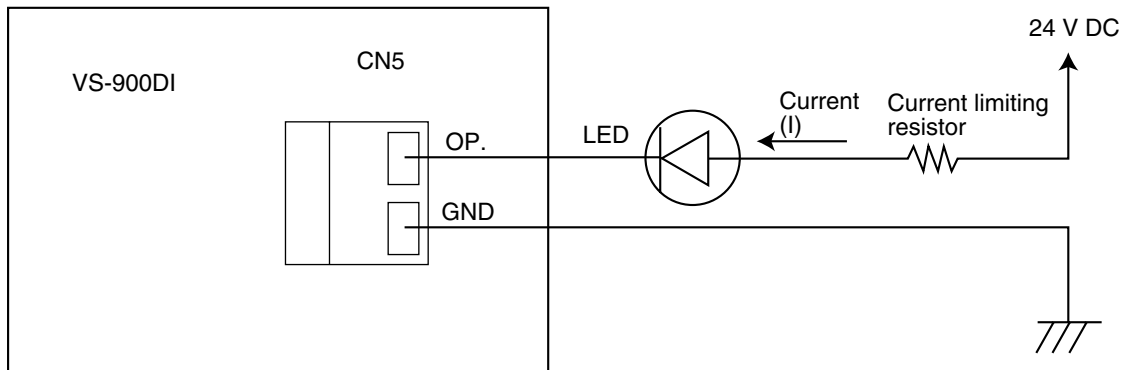

5.4.7. CN4 Input key (C/PTT/XFER/Test key) connection

Connect the input key to the switches from the CN4 connector as shown below. Each contact carries a current of 0.5 mA.

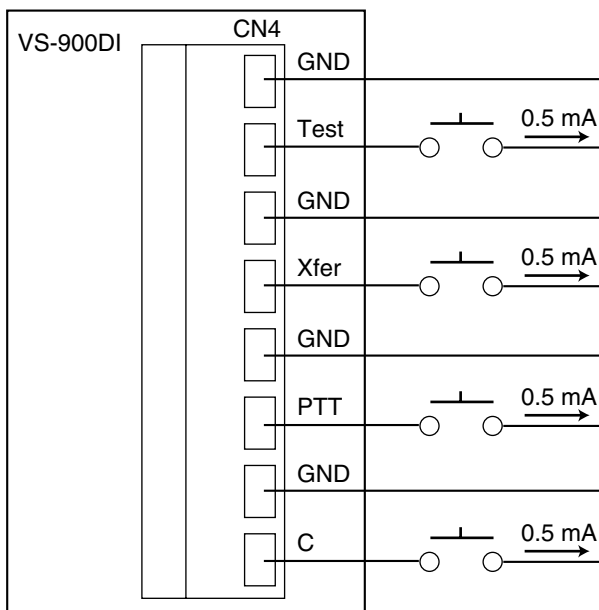

5.4.8. CN8 headset connection

- Use the headset with microphone sensitivity of -75 to -65 dB and speaker impedance of 200 to 400 Ω .
- Whether to insert a headset for response or to add a switch for response can be selected at the time of connection. The connection is as follows.
- If adding the switch, use the devices connected to CN8's Det. And G terminals as switches.
- If the headset microphone is of dynamic type, cut the jumper SJP1.
- Adjust the semi-fixed control VR1 for optimum microphone sensitivity.
- Adjust the semi-fixed control VR3 for optimum speaker sound volume.

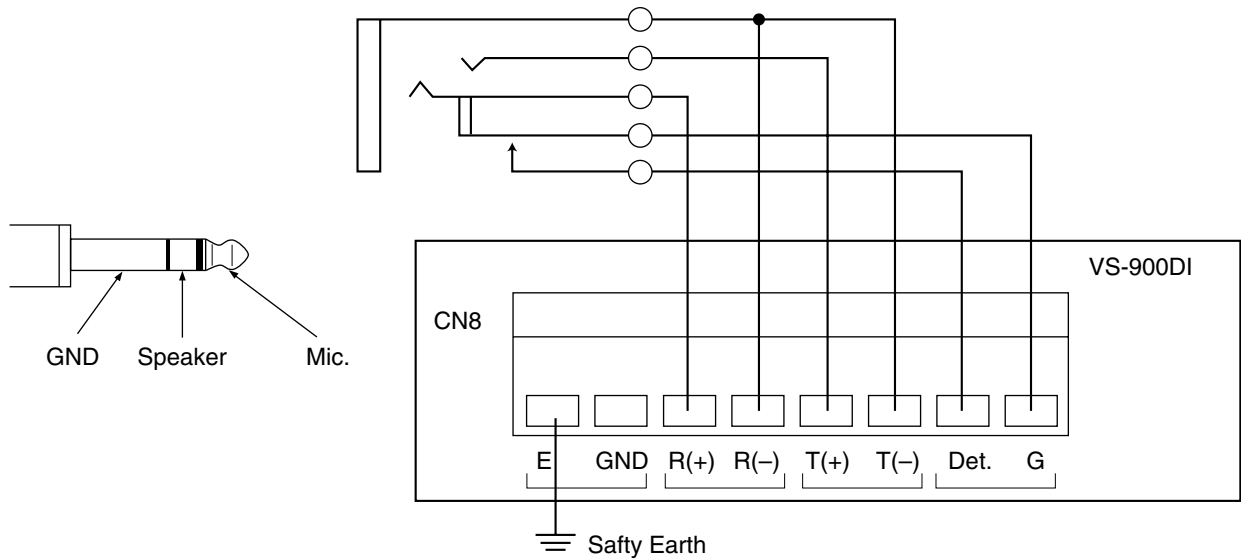

5.4.9. Earth grounded connection

Be sure to connect the earth ground from E terminal of CN8 screwless terminal as illustrated above.

5.4.10. CN9 microphone input connection

Use an electret microphone, and shielded cables for its wiring.
Pay attention to the polarity, and be sure to connect the signal side (+) to the ECGin terminal.

Note

Cut the jumper SJP2 on the VS-900DI card when using a dynamic microphone or externally-powered microphone. (This work results in cutting off the phantom power supply.)
Adjust the semi-fixed control VR2 for optimum microphone sensitivity.

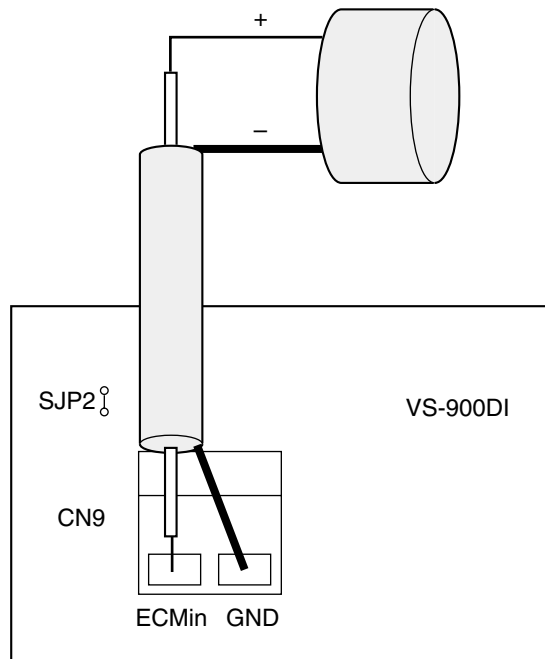

5.4.11. CN10 speaker output connection

Be sure to use the speaker with impedance of 8 Ω .
Power output derived from the card is 1 W maximum.
Adjust the semi-fixed control VR4 for optimum speaker sound volume.

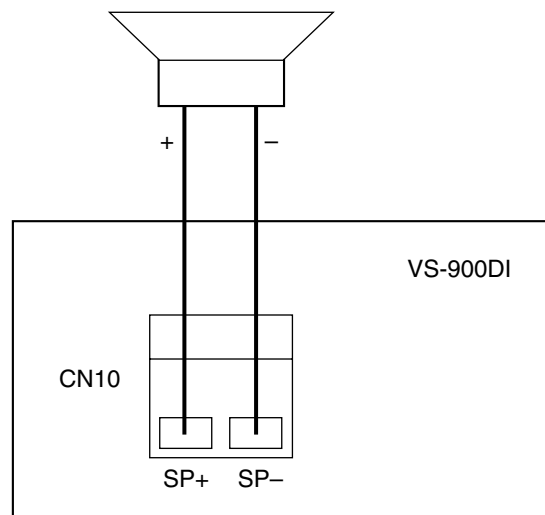

5.5. VS-910DI Connection

5.5.1. CN3 power supply terminal connection

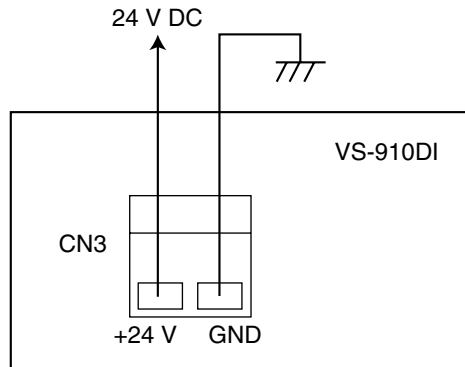

5.5.2. Calling station indication output connection

- The calling station indication output is connected to the LED from the 50-position Miniature Ribbon Plug* of CN5 according to the figure below. For the relationship between the CN5 connector pins and their corresponding outputs, refer to the table below.

* Equivalent to "CHAMP ®" IDC type (Amphenol type)

- Each output requires a current capacity of 24 V DC/100 mA.
- To use an LED, connect a current limiting resistor in series with it as the resistor is not built in the card.
- Determine the appropriate resistor value depending on the amount of current (I) necessary for indication elements (LED, etc.) to be used.

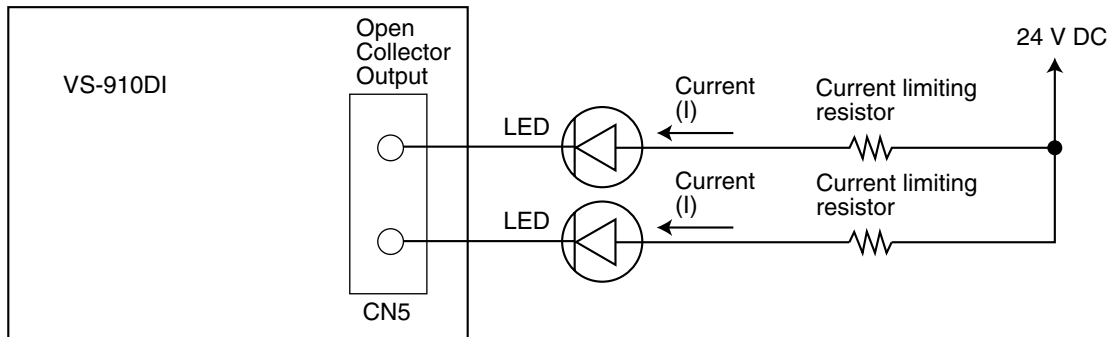

CALL-IN LED No.	Connector Pin No.	CALL-IN LED No.	Connector Pin No.	CALL-IN LED No.	Connector Pin No.	CALL-IN LED No.	Connector Pin No.
1	CN5-1	9	CN5-9	17	CN5-17	25	CN5-25
2	CN5-2	10	CN5-10	18	CN5-18	26	CN5-26
3	CN5-3	11	CN5-11	19	CN5-19	27	CN5-27
4	CN5-4	12	CN5-12	20	CN5-20	28	CN5-28
5	CN5-5	13	CN5-13	21	CN5-21	29	CN5-29
6	CN5-6	14	CN5-14	22	CN5-22	30	CN5-30
7	CN5-7	15	CN5-15	23	CN5-23	31	CN5-31
8	CN5-8	16	CN5-16	24	CN5-24	32	CN5-32
						GND	CN5-33 to CN5-50

5.5.3. Direct select input connection

Connect the direct select input from CN6's 50-position Miniature Ribbon Plug* as shown below. For the relationship between the CN6 connector pins and their corresponding inputs, refer to the table below. Each contact carries a current of 0.5 mA.

* Equivalent to "CHAMP ®" IDC type (Amphenol type)

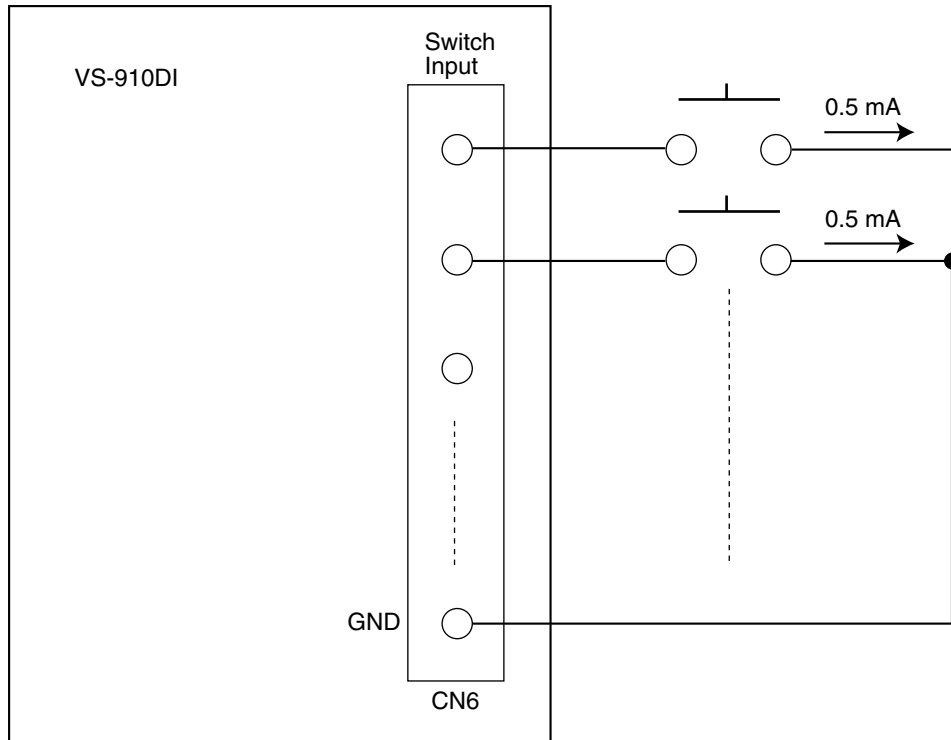

SELECT SW No.	Connector Pin No.	SELECT SW No.	Connector Pin No.	SELECT SW No.	Connector Pin No.	SELECT SW No.	Connector Pin No.
1	CN6-1	9	CN6-9	17	CN6-17	25	CN6-25
2	CN6-2	10	CN6-10	18	CN6-18	26	CN6-26
3	CN6-3	11	CN6-11	19	CN6-19	27	CN6-27
4	CN6-4	12	CN6-12	20	CN6-20	28	CN6-28
5	CN6-5	13	CN6-13	21	CN6-21	29	CN6-29
6	CN6-6	14	CN6-14	22	CN6-22	30	CN6-30
7	CN6-7	15	CN6-15	23	CN6-23	31	CN6-31
8	CN6-8	16	CN6-16	24	CN6-24	32	CN6-32
						GND	CN6-33 to CN6-50

5.5.4. External equipment control output connection

Connect the external equipment control output to the equipment to be controlled from CN4's 50-position Miniature Ribbon Plug* as shown below. For the relationship between the CN4 connector pins and their corresponding inputs, refer to the following table.

The contact capacity is 24 V DC/1 A.

* Equivalent to "CHAMP ®" IDC type (Amphenol type)

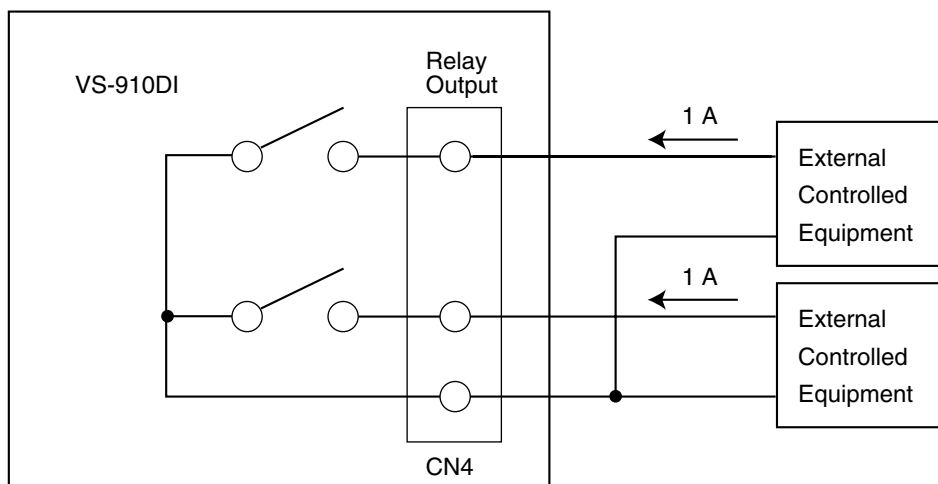

CONTROL OUTPUT No.	Connector Pin No.	CONTROL OUTPUT No.	Connector Pin No.	CONTROL OUTPUT No.	Connector Pin No.	CONTROL OUTPUT No.	Connector Pin No.
1	CN4-1	9	CN4-9	17	CN4-17	25	CN4-25
2	CN4-2	10	CN4-10	18	CN4-18	26	CN4-26
3	CN4-3	11	CN4-11	19	CN4-19	27	CN4-27
4	CN4-4	12	CN4-12	20	CN4-20	28	CN4-28
5	CN4-5	13	CN4-13	21	CN4-21	29	CN4-29
6	CN4-6	14	CN4-14	22	CN4-22	30	CN4-30
7	CN4-7	15	CN4-15	23	CN4-23	31	CN4-31
8	CN4-8	16	CN4-16	24	CN4-24	32	CN4-32
						COMMON	CN4-33 to CN4-50

5.5.5. VS-910DI's CN4/CN5/CN6 connections

Use a 50-position Miniature Ribbon Jack*¹ for connecting CN4/CN5/CN6 of the VS-910DI card. The size of the plug on the circuit board side is as illustrated below.

The size of the plug on the VS-910DI card

Unit: mm

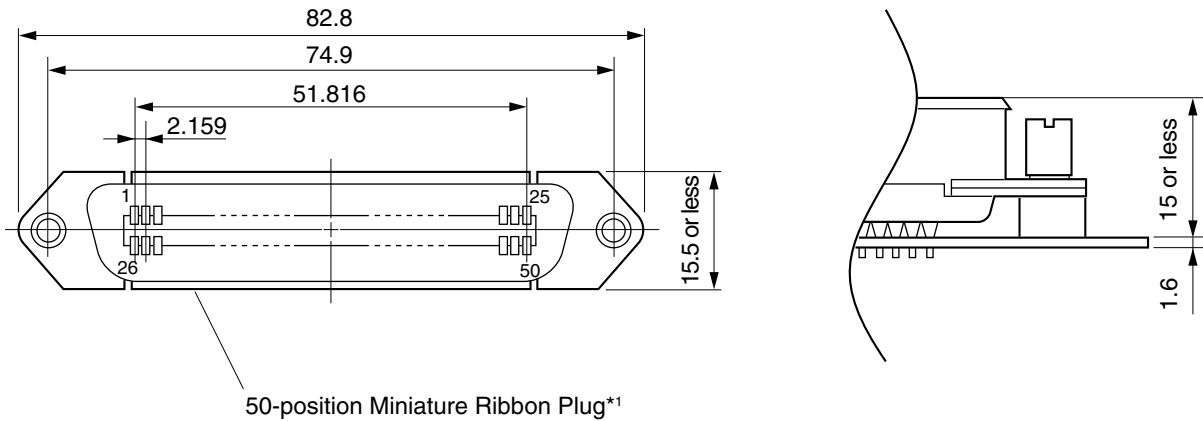

Depending upon the type of connector to be used, the space (W^{*2}) between circuit boards needs to be determined.

*¹ Equivalent to "CHAMP ®" IDC type (Amphenol type)

*² The maximum length W is 10 cm due to the limited length of a ribbon cable connecting between boards.

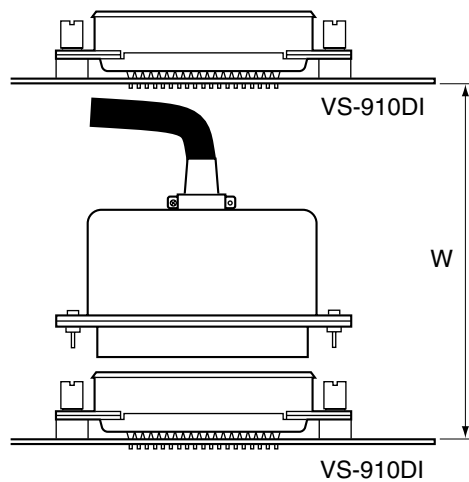

6. REGISTRATION

Use the VS-900 PC interface software to register the station No. for each key input.

6.1. Direct Select Setting

Connect the VS-900DI to the VS-900MF for setting.

Designate the exchange number, then perform the following settings:

Setting Item	Contents
Control output mode	Select the external equipment control output operation mode. Response-Activate: Make contact when conversation begins. Call-Activated: Make output when calls are initiated.

6.2. Direct Select Dial Setting

Connect the VS-900DI to other VS-900DI.

Designate both the exchange number and the master station address, then perform the following settings:

Setting Item	Contents
One-shot make duration	Set the one-shot make duration.
Dial number	Set the number to be programmed into each key. (If the station number is assigned to the dial number, the name programmed during exchange line setting is displayed in the "Name" item.)
Remote door control output number (Switch number)	Set the output number to be used in remote door control.

6.3. Programming PC Connection

Connect the VS-900DI to the programming PC by using an RS-232C cable as shown below.

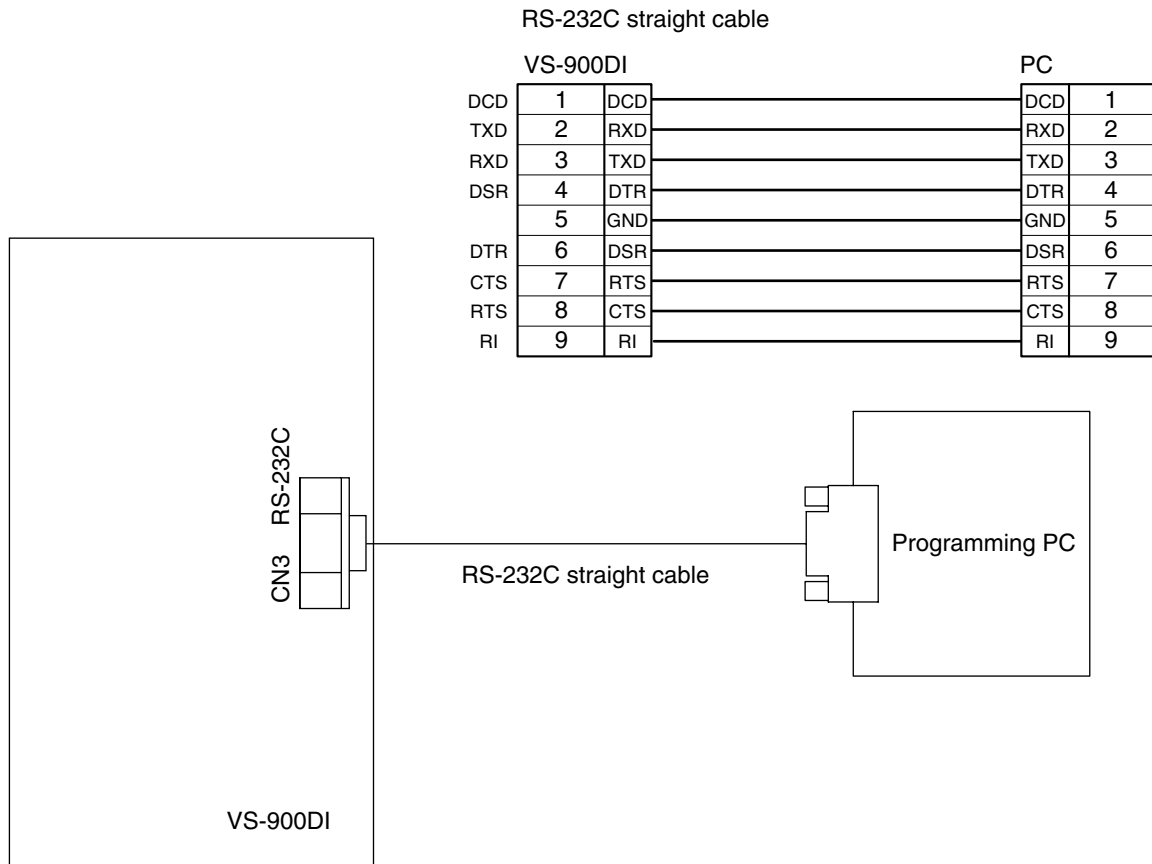

6.4. Programming Data Entry

6.4.1. Entry when the VS-900DI alone is used

Switch on the VS-900DI's power.
 Enter the set data. Do not switch off the power until LEDs 1 to 8 begin to flash, which indicates data registration completion.

6.4.2. Entry when the VS-900DI is connected to the VS-910DI

Switch on the power after checking for proper connections between the two cards, then enter the set data. Do not switch off power until LEDs 1 to 8 begin to flash, which indicates data registration completion.

7. OPERATION TEST

7.1. Operation Check by Means of the Test Switch

Using the test switch, operations of both the calling station indication output and external equipment control output can be checked.

- Step 1.** Push CN4's test key without connecting the card to the exchange, and enter test mode.
- Step 2.** Turn on and off indication outputs 1-32 and control outputs 1-32 on Card No. 1 first, and then check outputs 1-32 on Card No. 2 by turning them on and off. Similarly, repeat the same tests for up to Card No. 32.
- Step 3.** To quite the test mode, turn the power off, then turn it on again.

7.2. Check through Individual Operations

7.2.1. Checking VS-900DI/VS-910DI for proper operation without using the master station

- Step 1.** Connect the VS-900DI to the exchange.
- Step 2.** Dial with the direct select selection input to call the person you want to talk to.
- The LED connected to the calling station indication output lights, permitting synchronized operation of the devices connected to the external equipment control output.
 - Incoming calls can be responded to by means of the Direct Select input corresponding to the receiving indication. As in the above case, the LED connected to the calling station indication output also lights, permitting synchronized operation of the devices connected to the external equipment control output.

[Conversation through the Headset]

Connect the phone jack to the VS-900DI referring to p. 15 "CN8 headset connection."

- Step 3.** Connect the headset plug into the jack, and conversation can be made using the headset. The conversation type of "Duplex", "Press-to-talk", or "Voice-operated switching" depends on other party's type of unit and conversation mode.
- Step 4.** Press [C] key to terminate conversation.

[Conversation through the Microphone and Speaker]

Do not connect the headset.

- Step 3.** Conversation can be made using the microphone and speaker. The conversation type of "Duplex", "Press-to-talk", or "Voice-operated switching" depends on other party's type of unit and conversation mode.
- Step 4.** Press [C] key to terminate conversation.

7.2.2. Checking VS-900DI/VS-910DI for proper operation when using the master station

Here check the operation when only their Direct Select functions are used in combination with the master station (case when the master station is used for conversation).

- Step 1.** Connect the master station in series with the exchange.
- Step 2.** Using the Direct Select Input, dial to make a call, and converse with the connected party through the master station or instead of doing this, dial at the master station and converse with the connected party. The LED connected to the calling station indication output lights, permitting synchronized operation of the devices connected to the external equipment control output. Also, incoming calls can be responded to by means of the Direct Select input corresponding to the receiving indication. As in the above case, the LED connected to the calling station indication output also lights, permitting synchronized operation of the devices connected to the external equipment control output.
- Step 3.** The conversation can be terminated by means of on-hook operation or the [C] key on the master station or VS-900DI's input key or CN4's [C] key.

Tip

The call transfer function can also be used by means of the VS-900DI's transfer key (CN4's [Xfer] key).

8. FUNCTIONS AND OPERATION

8.1. Calling/Called Station Indication Output

Calling and called parties can be indicated on the corresponding LED indicators by making the LED indicators on the indicator panel that correspond to the stations for each master station.

1. Emergency station making a call: Quick flashes
2. Normal station making a call: Slow flashes
3. Station being called: Continuously lit
4. Conversation partner station: Continuously lit.
5. Station placed on hold: Continuously lit.
6. Station being scan-monitored: Continuously lit
7. Station under any other than the above conditions: Extinguished.

[System pre-programming]

To use the indication function, both the calling/called indication output and dial operation must be assigned by system programming.

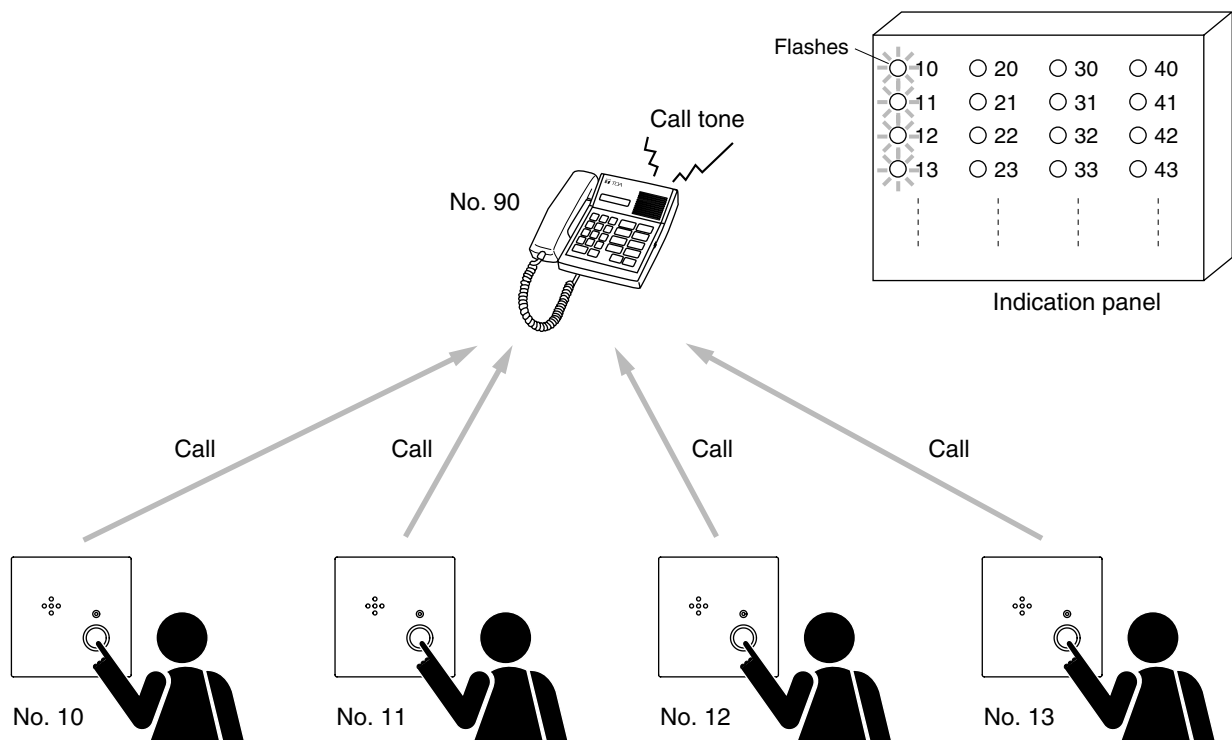

8.2. Direct Select Input

If an operation panel containing switches corresponding to the stations is prepared for each master station, a desired party can be called or a calling party can be responded to by simply pressing the corresponding switch.

[System pre-programming]

To use the above function, both the Direct Select input switch and dial operation must be assigned and programmed by system programming.

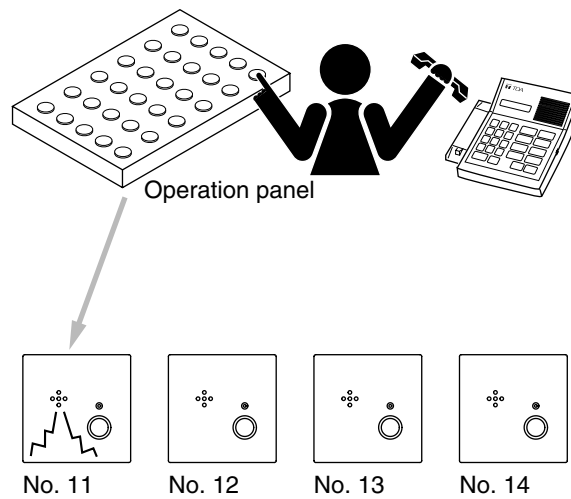

8.3. External Equipment Control Output

Connected external equipment can be controlled using the following 2 types of timings by making the control panel providing relay outputs that correspond to the stations for each master station.

8.3.1. CCTV interlock output

Contact points corresponding to the stations open and close in synchronization with operations such as calls from other station or conversation commencement. (For example, connection to the surveillance camera system creates a system which interlocks with video image output.)

[System pre-programming]

- To use the above function, both dial operation and external control output must be assigned and programmed by system programming.
- Select [Response-Activate] or [Call-Activated] by system programming as the condition to make the control output using the system programming.

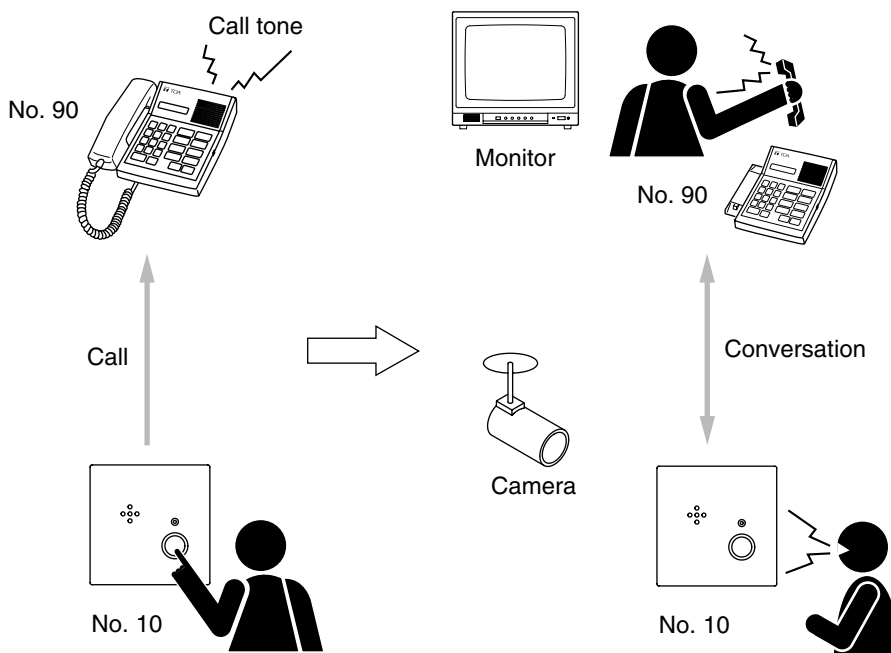

8.3.2. Remote door control output

Performing the following operations during conversation with another station makes (closes) the contact point corresponding to the conversation partner's station for a specified period of time. (For example, connection to the electric lock system creates the door lock control system.)

[System pre-programming]

- To use the above function, one-shot make output signals must be programmed by system programming for external control and dial operation assignment.
- The one-shot make duration can be set with the system programming.

[Remote door control operation]

Step 1. Press the [XFER] key during two-party conversations. (In the case of telephones, briefly press the hook switch.)

The current conversation is placed on hold, and a holding tone is transmitted to other party.

Step 2. Press [*] and [9].

The relay corresponding to the conversation partner is closed for a specified period of time.

(If connected to the electric lock system, for instance, the corresponding door lock can be released.)

Step 3. A confirmation tone sounds, restoring the original conversation.

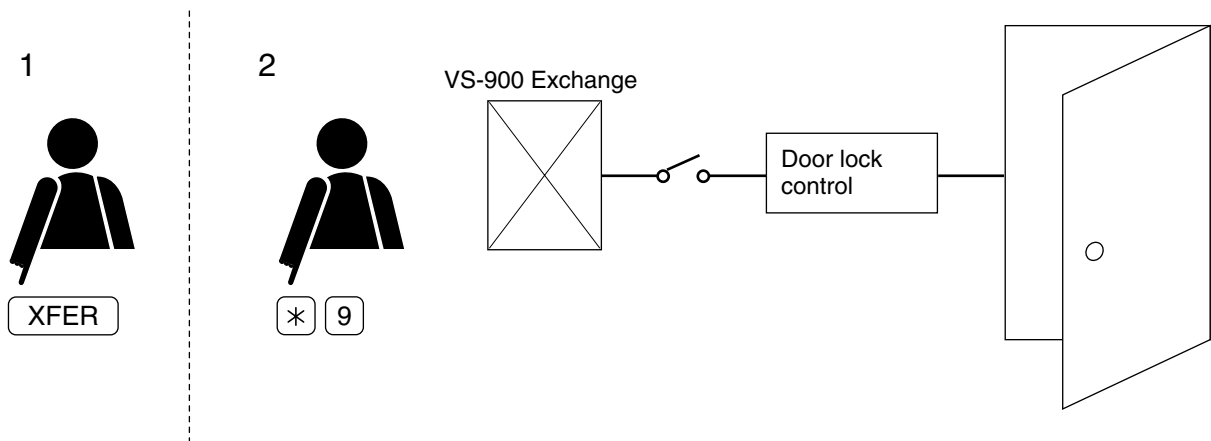

8.4. Conversation Using the Master Station

- Step 1.** Push the switch connected to the Direct Select Input (the "Direct Select Switch") to call the person you want to talk to.
(Dialing can be performed with the handset on-hook or off-hook.)
- Step 2.** A ringing tone is heard from the master station.
(This tone will be heard from the station's internal speaker if dialed with the handset on-hook.)
- Step 3.** Talk
- Step 4.** Replace the handset or push the [C] key to terminate the conversation.
(Either the [C] key on the master station or on the VS-900DI can be used.)

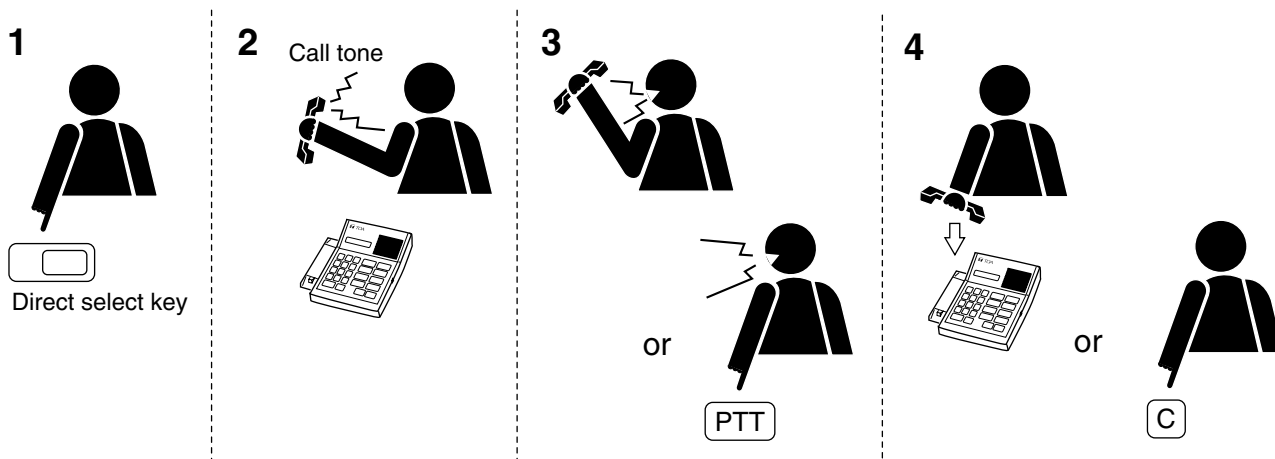

8.5. Conversation Using the VS-900DI and Not Using the Master Station

- Step 1.** Push the Direct Select Switch to call the person you want to talk to.
- Step 2.** Converse using the headset or the loudspeaker and microphone.
"Press-to-talk" conversation is also possible by pushing the [PTT] key.
- Step 3.** Push the [C] key to terminate the conversation.

Note

Pushing the Direct Select Switch again will not terminate the conversation.

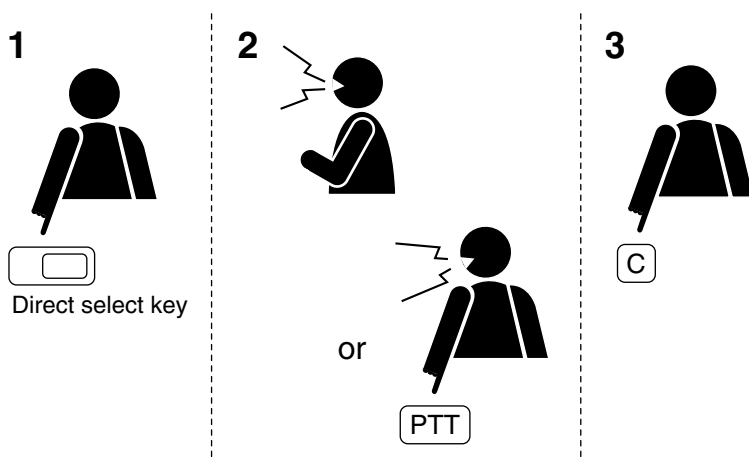

9. SPECIFICATIONS

[VS-900DI]

Power Source	24 V DC \pm 10%/1 A, 2-pole screwless terminal* ²
Maximum Cable Length to Exchange	1.5 km (including the additional master station line from the VS-900DI) when the cable guage is AWG22
Maximum Number of Connectable VS-900DI Cards	4 cards per exchange, 64 cards per system (16 tie-lined exchanges)
Function Key Input	One each of [C], [PTT], [Xfer], and [Test] keys, dry contact, 5 V DC/0.5 mA, contact resistance: 50 Ω or less, 8-pole screwless terminal* ²
Commuication Line	1 line for VS-900 exchange (VS-900MS card) and 1 line for MS-900 master station, 1 6-position/4-contact modular jack for each line
In-use Indication Output	Open collector output, 24 V DC/approx. 100 mA, 2-pole screwless terminal* ²
Electret Microphone Input	Microphone sensitivity: -75 to -65 dB* ¹ , phantom power supply (power supply can be cut off), 2-pole screwless terminal* ²
Speaker Output	Speaker impedance: 8 Ω , power output: 1 W maximum, 2-pole screwless terminal* ²
Headset Connection	Microphone sensitivity: -75 to -65 dB* ¹ , speaker impedance: 200 to 400 Ω , detection jack contact input [Det.]: 5 V DC/10 mA, contact resistance: 10 Ω or less, 8-pole screwless terminal* ² (Headset can also be turned on/off using the manual switch instead of the jack contact input.)
PC Interface	RS-232C D-sub connector (9 poles, female type)

*1 0 dB = 1 V(rms)

*² Usable cable

Bared-core length: 5 – 6 mm

Cross section area: 0.14 – 2.5 mm²

Note: The design and specifications are subject to change without notice for improvement.

• Accessories

Ferrite clamp SFC-8	2
Modular cord (3 m)	1

[VS-910DI]

Power Source	24 V DC \pm 10%/1 A, 2-pole screwless terminal* ¹
Maximum Number of VS-910DIs per VS-900DIs	32
Maximum Number of Ports per VS-910DI	<ul style="list-style-type: none"> • 32 switch inputs (for calling and response switch operation) • 32 open collector outputs (for LED indication of incoming and outgoing calls) • 32 relay outputs (call- or response-activated relay output)
Maximum Number of Ports per Full VS-910DI-Mounted System	<ul style="list-style-type: none"> • 1024 switch inputs (for calling and response switch operation) • 1024 open collector outputs (for LED indication of incoming and outgoing calls) • 1024 relay outputs (call- or response-activated relay output)
Switch Input	32 inputs (for custom-made direct select key operation for calling or response), dry contact, 5 V DC/0.5 mA, contact resistance: 50 Ω or less, 50-position Miniature Ribbon Plug* ²
Open Collector Output	32 outputs (for LED indication of incoming and outgoing calls), 24 V DC/approx. 100 mA, 50-position Miniature Ribbon Plug* ²
Relay Output	32 relay outputs, call- or response-activated relay output, normal open output, 24 V DC/1 A, 50-position Miniature Ribbon Plug* ²

*¹ Usable cable

Bared-core length: 5 – 6 mm

Cross section area: 0.14 – 2.5 mm²

*² Equivalent to "CHAMP ®" IDC type (Amphenol type)

Note: The design and specifications are subject to change without notice for improvement.

[Functions common to both models]

- Direct select key input (Up to 16 dial numbers can be registered into each key.)
- Selected station key's dial signal output (100 pps)
- Calling priority level indication (distinguishable by LED flashing speed)
- Conversation status indication (by steady-on LED)
- Call- or response-activated relay output (either activation mode selectable)
- MS-900 master station conversation (User-designed device can be used instead of MS-900.)

Note: For the function setting and mode selection, refer to the "VS-900 SETUP SOFTWARE MANUAL."

