

WIRELESS TUNERS

WT-5800

WT-5805

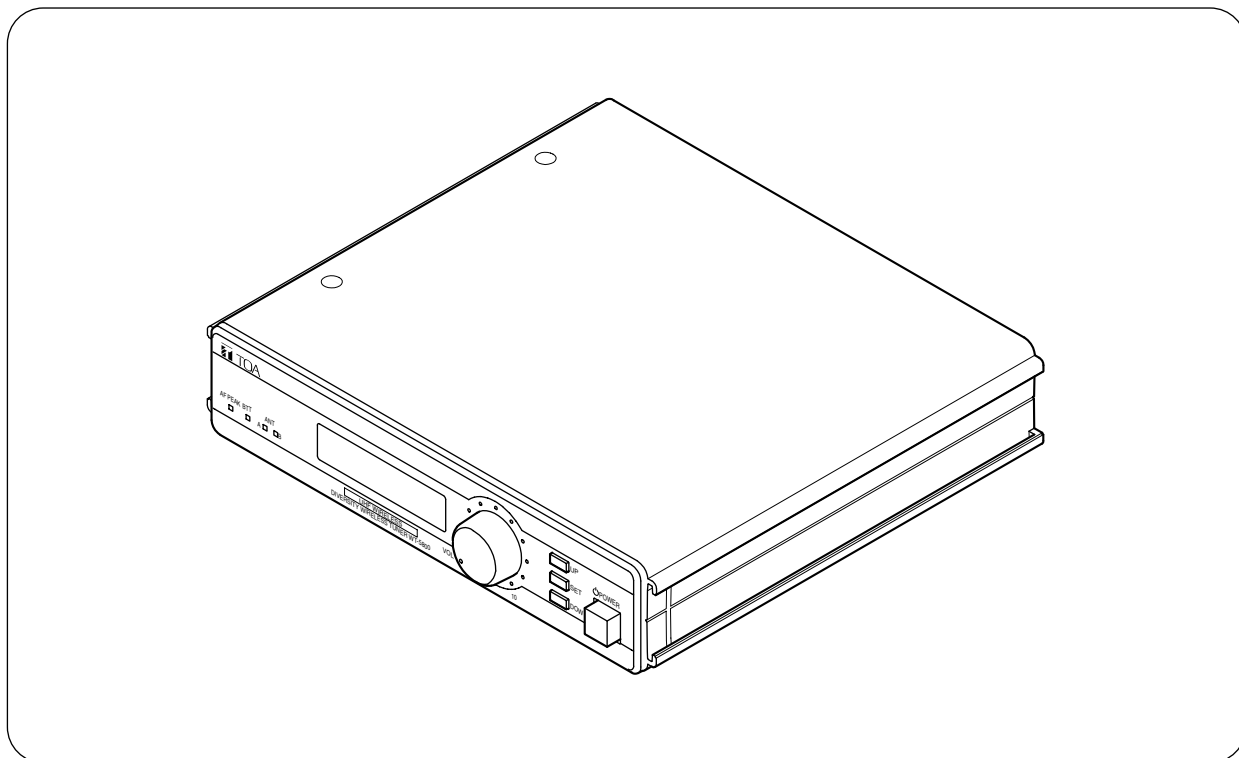

TABLE OF CONTENTS

1. SAFETY PRECAUTIONS	2	7. HOW TO CHECK AND DEAL	
2. GENERAL DESCRIPTION	3	WITH INTERFERENCE	9
3. FEATURES	3	8. CONNECTION EXAMPLES	10
4. HANDLING PRECAUTIONS	4	9. RACK MOUNTING	11
5. NOMENCLATURE AND FUNCTIONS		10. SPECIFICATIONS	12
Front	4	Accessories	12
Rear	5	Optional products	12
6. OPERATION			
6.1. Basic Operation	5		
6.2. Function Settings	6		

Thank you for purchasing TOA's Wireless Tuner.

Please carefully follow the instructions in this manual to ensure long, trouble-free use of your equipment.

1. SAFETY PRECAUTIONS

- Be sure to read the instructions in this section carefully before use.
- Make sure to observe the instructions in this manual as the conventions of safety symbols and messages regarded as very important precautions are included.
- We also recommend you keep this instruction manual handy for future reference.

Safety Symbol and Message Conventions

Safety symbols and messages described below are used in this manual to prevent bodily injury and property damage which could result from mishandling. Before operating your product, read this manual first and understand the safety symbols and messages so you are thoroughly aware of the potential safety hazards.



WARNING

Indicates a potentially hazardous situation which, if mishandled, could result in death or serious personal injury.

When Installing the Unit

- Do not expose the unit to rain or an environment where it may be splashed by water or other liquids, as doing so may result in fire or electric shock.
- Use the unit only with the voltage specified on the unit. Using a voltage higher than that which is specified may result in fire or electric shock.
- Do not cut, kink, otherwise damage nor modify the power supply cord. In addition, avoid using the power cord in close proximity to heaters, and never place heavy objects -- including the unit itself -- on the power cord, as doing so may result in fire or electric shock.
- Avoid installing or mounting the unit in unstable locations, such as on a rickety table or a slanted surface. Doing so may result in the unit falling down and causing personal injury and/or property damage.
- To prevent lightning strikes, install the unit at least five meters away from a lightning rod, and yet within the protective range (angle of 45°) of the lightning conductor. Lightning strikes may cause a fire, electric shock or personal injury.
- Since the unit is designed for in-door use, do not install it outdoors. If installed outdoors, the aging of parts causes the unit to fall off, resulting in personal injury. Also, when it gets wet with rain, there is a danger of electric shock.

When the Unit is in Use

- Should the following irregularity be found during use, immediately switch off the power, disconnect the power supply plug from the AC outlet and contact your nearest TOA dealer. Make no further attempt to operate the unit in this condition as this may cause fire or electric shock.
 - If you detect smoke or a strange smell coming from the unit.
 - If water or any metallic object gets into the unit
 - If the unit falls, or the unit case breaks
 - If the power supply cord is damaged (exposure of the core, disconnection, etc.)
 - If it is malfunctioning (no tone sounds.)
- Do not place cups, bowls, or other containers of liquid or metallic objects on top of the unit. If they accidentally spill into the unit, this may cause a fire or electric shock.
- Do not touch the unit's antennas during thunder and lightning, as this may result in electric shock.



CAUTION

Indicates a potentially hazardous situation which, if mishandled, could result in moderate or minor personal injury, and/or property damage.

When Installing the Unit

- Never plug in nor remove the power supply plug with wet hands, as doing so may cause electric shock.
- When unplugging the power supply cord, be sure to grasp the power supply plug; never pull on the cord itself. Operating the unit with a damaged power supply cord may cause a fire or electric shock.
- When moving the unit, be sure to remove its power supply cord from the wall outlet. Moving the unit with the power cord connected to the outlet may cause damage to the power cord, resulting in fire or electric shock. When removing the power cord, be sure to hold its plug to pull.
- The socket outlet shall be installed near the equipment and shall be easily accessible.
- Avoid installing the unit in humid or dusty locations, in locations exposed to the direct sunlight, near the heaters, or in locations generating sooty smoke or steam as doing otherwise may result in fire or electric shock.
- Leave the installation of an antenna to your TOA dealer because the installation requires expert knowledge. The falling of an antenna may cause electric shock.

When the Unit is in Use

- Do not place heavy objects on the unit as this may cause it to fall or break which may result in personal injury and/or property damage. In addition, the object itself may fall off and cause injury and/or damage.
- Make sure that the volume control is set to minimum position before power is switched on. Loud noise produced at high volume when power is switched on can impair hearing.
- Never open the unit case as there are high temperature parts inside the unit, which may cause a burn if touched. Refer all servicing to your nearest TOA dealer.
- Use the dedicated AC-DC adapter for the unit. Note that the use of other adapter may cause a fire.
- If dust accumulates on the power supply plug or in the wall AC outlet, a fire may result. Clean it periodically. In addition, insert the plug in the wall outlet securely.
- Switch off the power, and unplug the power supply plug from the AC outlet for safety purposes when cleaning or leaving the unit unused for 10 days or more. A fire or electric shock may result.

2. GENERAL DESCRIPTION

The WT-5800/5805 Wireless Tuner is designed for use on the UHF band, and suitable for vocal or speech reinforcement applications. It features a compander circuit which minimizes the influence of ambient noise.

3. FEATURES

- 64 different operating frequencies (4 banks x 16 channels)
- An optimized PLL-synthesizer drastically minimizes the oscillation frequency drift resulting from the ambient temperature changes.
- The Scan function indicates available idle channels and is useful when changing the operating frequency.
- The LCD screen indicates the current operating frequency, as well as RF and AF levels.
- Antenna distribution outputs (WT-5800 only) and audio cascade inputs facilitate connection of another unit to build a dual-channel system.
- Compact size and high reliability

4. HANDLING PRECAUTIONS

- Make sure that the power switch is switched OFF after use.
- When mounting in an equipment rack, select the position which does not expose the unit to high temperature.
- When installing, keep the unit as far away as possible from fluorescent lamps, digital equipment, personal computers, and other equipment which generate high frequency noise.
- Only the same bank wireless systems can be used in the same location. Avoid using the systems in combination with those of different banks because interference or noise could be generated.
- Wireless tuners to be installed in the same location must differ from each other in channel number. Setting them for the same channel number could result in noise. Wireless microphones must be identical to wireless tuners in both bank and channel numbers.
- When using two or more wireless microphones, keep them at least 50 cm away from each other to avoid malfunctions or noise.
- Keep the wireless microphone at least 3 m away from the receiving antenna. Using the microphone in close proximity to the antenna could result in malfunctions or noise.
- Be sure to connect at least two receiving antennas (one each for Channels A and B).

5. NOMENCLATURE AND FUNCTIONS

[Front]

This figure represents WT-5800.

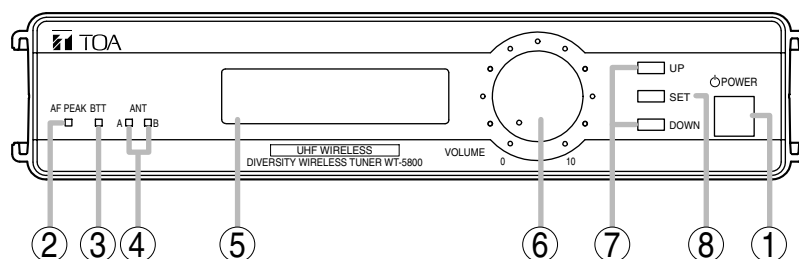

1. Power switch

Press this switch to turn the power on, and press it again to turn off the power.

2. AF peak lamp

Lights when the output level reaches the point of about 3 dB below the clipping level.

3. Battery alarm lamp

Lights when the battery voltage in the corresponding wireless microphone becomes low.

4. Reception lamps

Either lamp of A (left) or B (right) lights yellow when the tuner receives a radio signal.

5. LCD screen

Displays the receiving frequency, and RF/AF levels in 6 steps when the unit is in normal operating state.

In setting mode, the screen displays the setting items and their contents.

6. Volume control

Adjusts an output level.

7. Up/Down keys

Select the setting items displayed on the screen.

8. Set key

Brings the unit in setting mode when pressed in normal operating state. In setting mode, pressing the Set key determines the selected setting item and registers its contents.

[Rear]

This figure represents WT-5800.

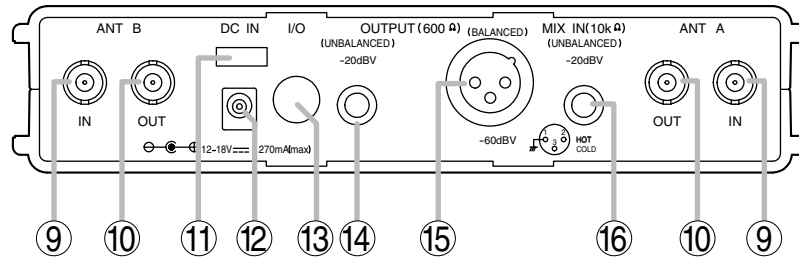

9. Antenna input A, B

For signal routing A. Input: 75 Ω, BNC
 For the wireless system covering a relatively narrow area, use the supplied two rod antennas, which should be set up at a 45° angle outwards from a vertical line.

10. Antenna distribution output A, B (WT-5800 only)
 75 Ω, BNC

11. Cable hanger

Hook the power cable onto this part.

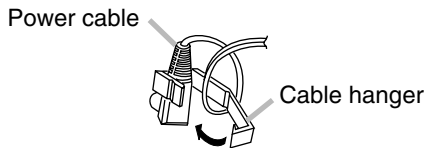

12. DC input jack

Connect the power cable of the supplied AC-DC adapter to this jack.

13. I/O port

Used for service only.

14. AF output

Unbalanced phone jack

15. AF output

Balanced XLR connector, male type
 (Pin #2: Hot)

16. AF mixing input (Unbalanced)

Connects to other unit's AF output.
 Input level: -20 dB, 10 kΩ (0 dB = 1 V)

6. OPERATION

6.1. Basic Operation

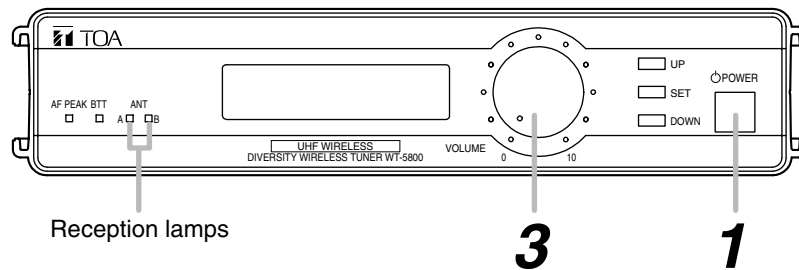

Step 1. Turn the power on, and the LCD screen comes to display the receiving frequency and RF/AF levels.

Step 2. Set the microphone switch to the ON position.
 The reception lamp lights when the tuner receives the same frequency signal.

Step 3. Adjust the volume control.
 The output level increases as the control is rotated clockwise, and decreases as rotated counterclockwise.

6.2. Function Settings

[Keys used in setting mode]

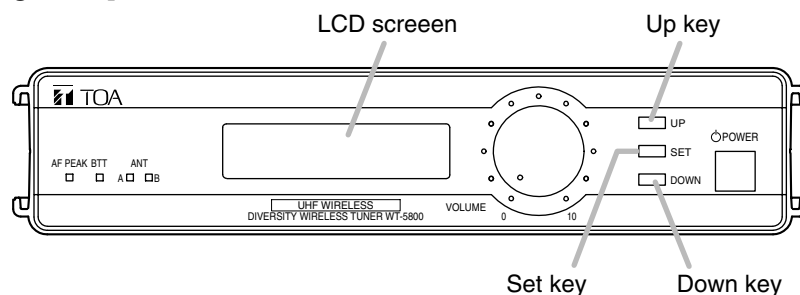

Setting items displayed on the LCD screen

The display cycles through the indications "SET CHANNEL," "SET BANK," "SET SQ LEVEL," "SET LCD POWER," CHANNEL CHECK," "RF CHECK," "About Model" and "Exit" with each depression of the Up key, or the Down key for the reverse action.

6.2.1. Channel (frequency) setting

- Step 1.** Press the Set key for about a second until the screen displays the first setting item "SET CHANNEL." The unit is placed in setting mode.
- Step 2.** Press the Set key, and the screen displays the currently-set channel and frequency with the prefix ">=" indication. (Example: >=8: 805.000 MHz)
- Step 3.** Select the desired channel/frequency with the Up or Down key. The display cycles through the contents with each depression of the Up or Down key.
- Step 4.** Press the Set key to register the selected channel/frequency. This terminates the Channel (frequency) setting, and the display returns to the "SET CHANNEL" indication.
Note
When leaving the original channel/frequency unchanged, select "Exit" with Up or Down key and press the Set key. Then, the display returns to the "SET CHANNEL" indication.
- Step 5.** When any other setting is not needed, select "Exit" with the Up or Down key and press the Set key. The unit returns to the normal operating state.

6.2.2. Bank number/frequency setting

- Step 1.** Press the Set key for over a second to place the unit in setting mode.
- Step 2.** Select the setting item "SET BANK" with the Up or Down key.
- Step 3.** Press the Set key again, and the screen displays the currently-set Bank number and frequency with the prefix ">=" indication. (Example: >=1:7 805.000 MHz)
- Step 4.** Select the desired Bank number/frequency with the Up or Down key. The display cycles through the contents with each depression of the Up or Down key.
- Step 5.** Press the Set key to register the selected Bank number/frequency. This terminates the Bank number/frequency setting, and the display returns to the "SET BANK" indication.
Note
When leaving the original Bank number/frequency unchanged, select "Exit" with Up or Down key and press the Set key. Then, the display returns to the "SET BANK" indication.
- Step 6.** When any other setting is not needed, select "Exit" with the Up or Down key and press the Set key. The unit returns to the normal operating state.

6.2.3. Squelch level setting

The WT-5800/5805 tuner has the squelch function that virtually eliminates ambient noise and unwanted other wireless microphone systems by silencing the output when the signal received is lower than a certain level of signal strength. This strength level can be varied by means of the squelch control.

Step 1. Press the Set key for over a second to place the unit in setting mode.

Step 2. Select the setting item "SET SQ LEVEL" with the Up or Down key.

Step 3. Press the Set key, and the squelch level adjustment display "RF >" appears on the screen.

Step 4. Set the squelch level referring to the on-screen bar-graph meter (6 segments) which can be changed with Up or Down key.

Step 5. Press the Set key to register the selected value.

This terminates the Squelch level setting, and the display returns to the "SET SQ LEVEL" indication.

Note

When leaving the original value unchanged, select "Exit" with Up or Down key and press the Set key. Then, the display returns to the "SET SQ LEVEL" indication.

Step 6. When any other setting is not needed, select "Exit" with the Up or Down key and press the Set key. The unit returns to the normal operating state.

The squelch level ranges from "0" to "6." The wireless tuner's sensitivity is the highest and radio signals can be received in wide areas when the "0" level is selected, while the "6" level makes the sensitivity the lowest, limiting signal reception only to narrow areas.

The wireless microphone's signal transmission distance varies largely depending on its ambient conditions. The table below provides guidelines on the squelch level vs. transmission distance.

Squelch Level	0	1	2	3	4	5	6
Transmission Distance (%)	100	85	70	50	30	20	15

Note: Transmission distance is a relative ratio with respect to 100% at "0" level.

Tips

- Set the control to the "0" position in locations free from interference.
- Set the control to the position that does not cause any reception loss of wireless microphone signals.

6.2.4. LCD backlight brightness adjustment

Step 1. Press the Set key for over a second to place the unit in setting mode.

Step 2. Select the setting item "SET LCD POWER" with the Up or Down key.

Step 3. Press the Set key, and the brightness adjustment display appears on the screen.

Step 4. Select either "HIGH (Bright)" or "LOW (Dark)" with the Up or Down key.

Step 5. Press the Set key to register the selected brightness level.

This terminates the Brightness setting, and the display returns to the "SET LCD POWER" indication.

Step 6. When any other setting is not needed, select "Exit" with the Up or Down key and press the Set key. The unit returns to the normal operating state.

6.2.5. Channel detection

Step 1. Press the Set key for over a second to place the unit in setting mode.

Step 2. Select the setting item "CHANNEL CHECK" with the Up or Down key.

Step 3. Press the Set key.

Channel detection begins, and an idle channel number with frequency is displayed on the screen. When 2 or more idle channels exist, each of them can be displayed in sequence with the Up or Down key.

If no idle channel is detected, "Vacant CHANNEL doesn't exist" is displayed.

Step 4. Press the Set key to register the selected channel.

This terminates the Channel detection, and the display returns to the "CHANNEL CHECK" indication.

Note

When leaving the original channel unchanged, select "Exit" with Up or Down key and press the Set key. Then, the display returns to the "CHANNEL CHECK" indication.

Step 5. When any other setting is not needed, select "Exit" with the Up or Down key and press the Set key.

The unit returns to the normal operating state.

6.2.6. RF check

Step 1. Adjust the volume control to decrease the volume. (Big noise is output if the unit is placed in RF check mode when no signal is present.)

Step 2. Press the Set key for over a second to place the unit in setting mode.

Step 3. Select the setting item "RF CHECK" with the Up or Down key.

Step 4. Press the Set key to check idle channels by hearing sound.

The receiving antenna alternates between Antenna A and Antenna B with each depression of the Up or Down key.

Step 5. Press the Set key again after check completion.

This exits the RF check mode, and the display returns to the "RF CHECK" indication.

Step 6. When any other setting is not needed, select "Exit" with the Up or Down key and press the Set key.

The unit returns to the normal operating state.

6.2.7. Confirming Firmware Version

Step 1. Press the Set key for over a second to place the unit in setting mode.

Step 2. Select the setting item "About Model" with the Up or Down key.

Step 3. Press the Set key to display the firmware version.

Step 4. Press the Set key again to exit the firmware display mode.

The display returns to the "About Model" indication.

Step 5. When any other setting is not needed, select "Exit" with the Up or Down key and press the Set key.

The unit returns to the normal operating state.

6.2.8. Rewriting the inner Emphasis circuit data

By using the optional RW-4800, data written in the built-in Emphasis circuit can be changed to improve noise suppression. For its method, refer to the instruction manual supplied with the RW-4800. If changed, the circuit of the WM-5220/5320 series Wireless microphone should also be changed. The wireless tuners are compatible with the WM-4200 and WM-4300 Wireless microphones when shipped from the factory. Once this change has been performed on the tuners, however, no more compatibility is ensured.

Tip

Emphasis circuit works in such way that it increases signal strength at high frequencies in the wireless microphone, and decreases to the original signal level at the tuner, thereby resulting in noise reduction. The post-compressor Emphasis is adapted in the tuners when shipped from the factory, and changed to the pre-compressor Emphasis when the circuit data is updated.

7. HOW TO CHECK AND DEAL WITH INTERFERENCE

[Order of Actions (Action Flowchart)]

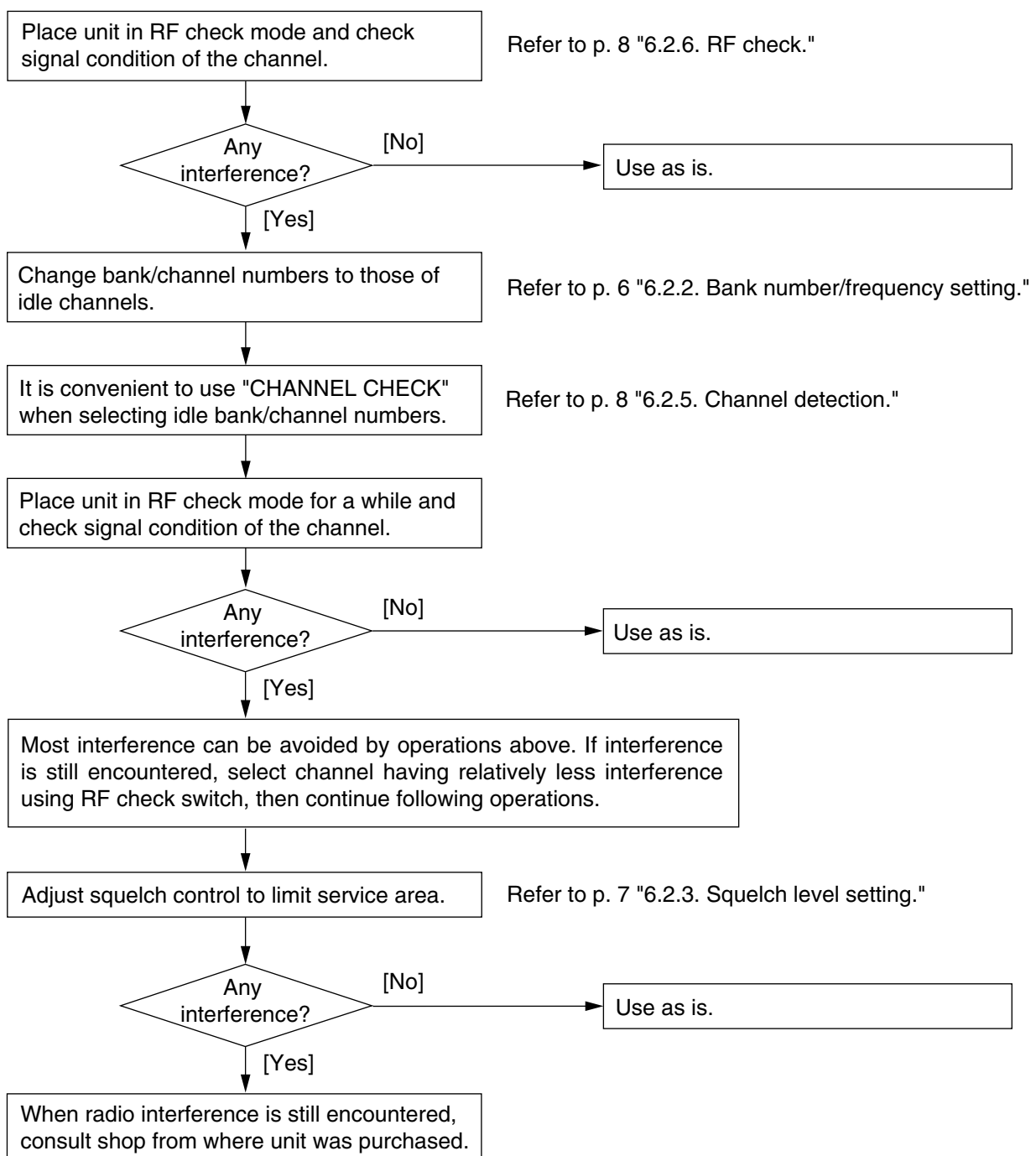

8. CONNECTION EXAMPLES

Be sure to connect at least two receiving antennas (one each for Channels A and B).

[Example 1]

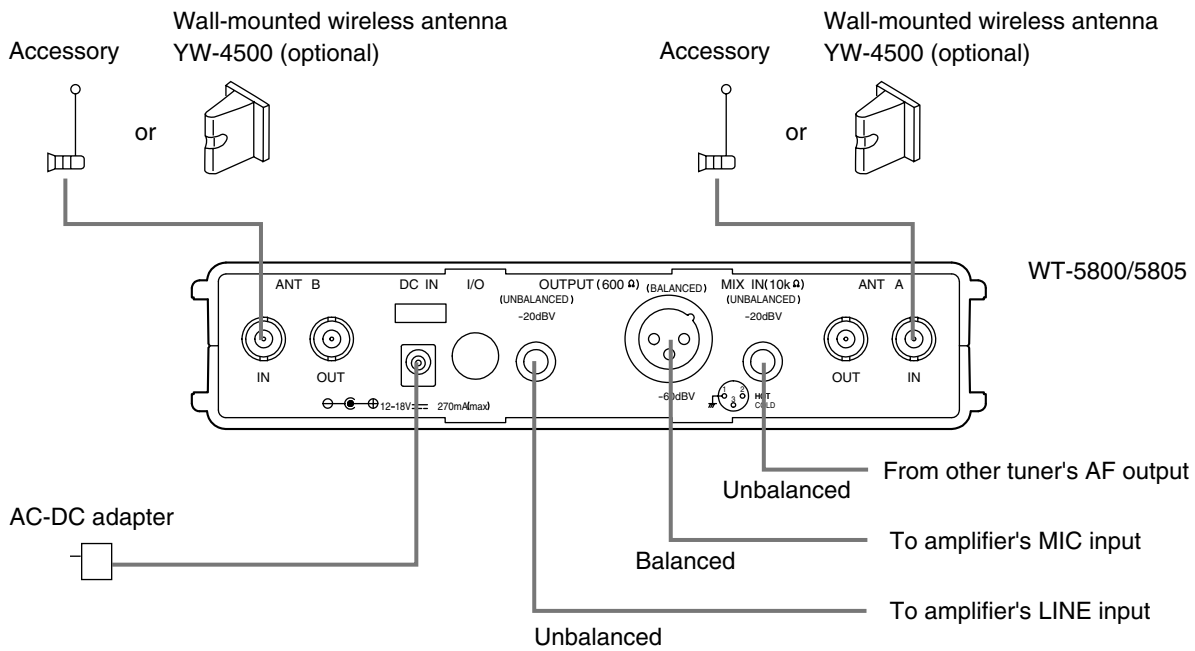

[Example 2]

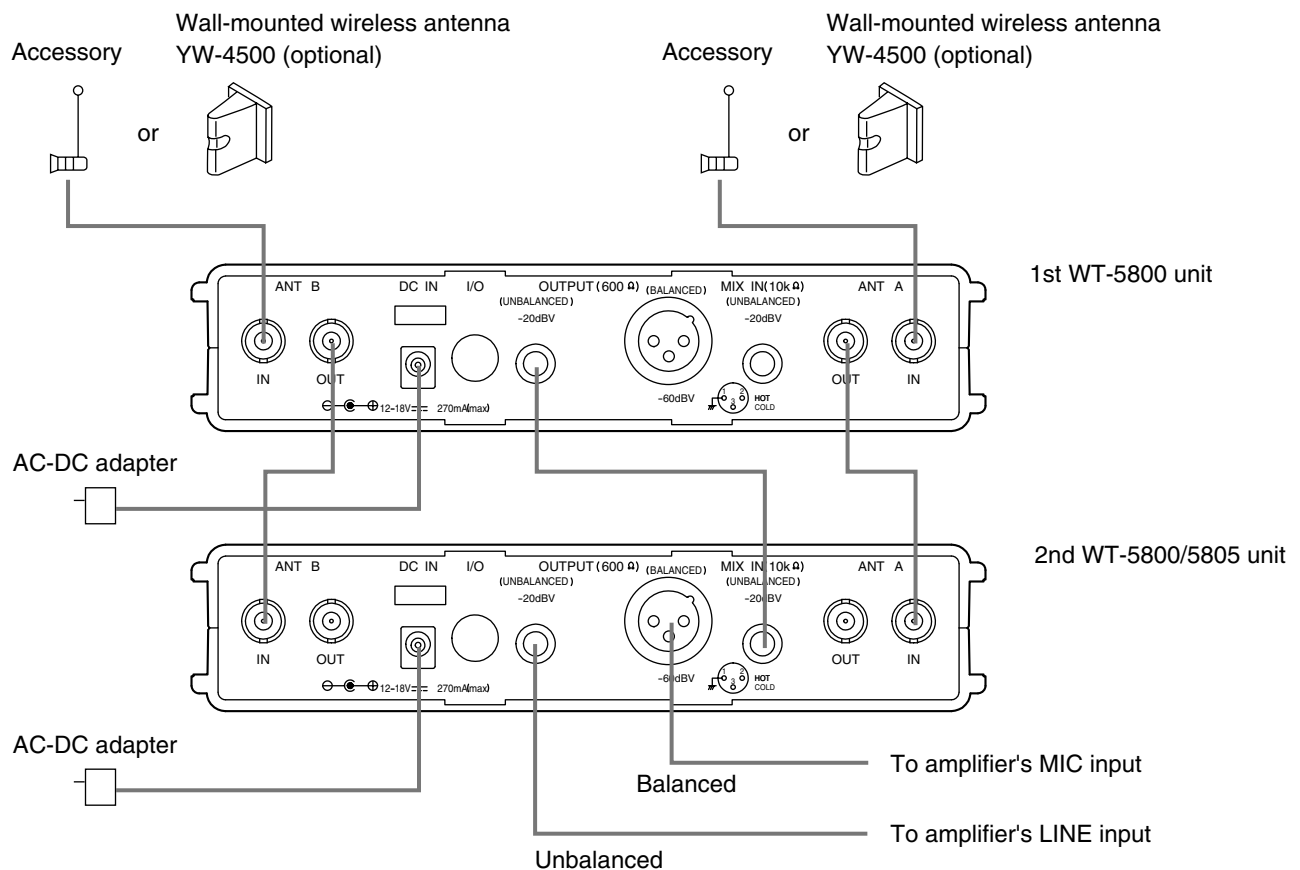

9. RACK MOUNTING

- When mounting one WT-5800/5805 unit, use an optional mounting kit MB-WT3.

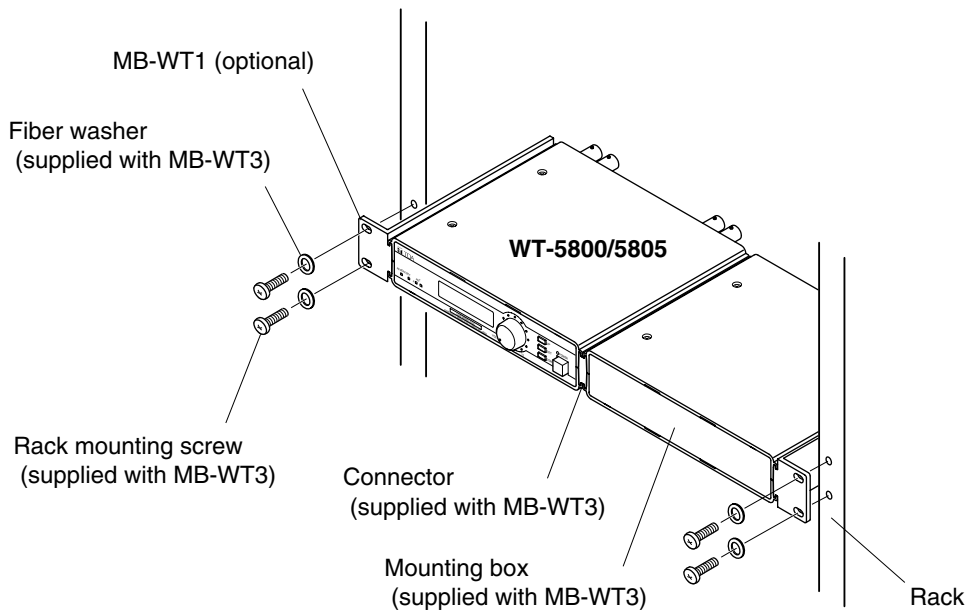

- When mounting two WT-5800/5805 units, use an optional mounting kit MB-WT4.

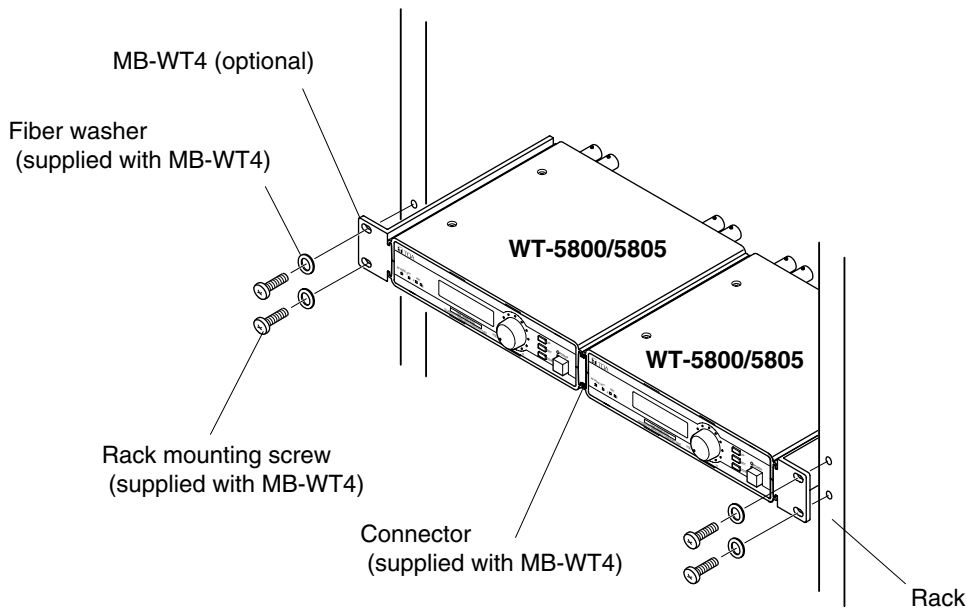

10. SPECIFICATIONS

Model Number	WT-5800	WT-5805
Power Source	AC mains (Supplied AC-DC adapter must be used.)	
Power Consumption	250 mA (12 V DC)	200 mA (12 V DC)
Receiving Frequency	692 – 865 MHz, UHF	
Selectable Channel	64 selectable frequencies	
Receiving System	Double super-heterodyne	
Diversity System	Space diversity (true diversity)	Space diversity
Mixing Output	MIC: -60 dB*, 600 Ω, balanced, XLR-3-31 type connector LINE: -20 dB*, 600 Ω, unbalanced, phone jack	
Mixing Input	-20 dB*, 10 kΩ, unbalanced, phone jack	
Antenna Input	75Ω, BNC (phantom powering for antenna), 9 V DC, 30 mA (max)	
Antenna Output	75Ω, BNC (Gain 0 dB)	—
Receiving Sensitivity	Over 90 dB, S/N ratio (20 dBμV input, 40 kHz deviation)	
Squelch Sensitivity	18 – 40 dBμV variable	
Squelch System	Using together of noise SQ, carrier SQ and tone SQ	
Tone Frequency	32.768 kHz	
Indicator	Audio (6 steps), RF (6 steps), ANT A/B, Audio (peak), Battery alarm	
Channel Check	Usable frequencies scanning	
S/N Ratio	Over 110 dB (A-weight, unbalanced output)	
Harmonic Distortion	Under 1% (typical)	
Frequency Response	100 – 15,000 Hz, ±3 dB	
Operating Temperature	-10°C to +50°C	
Finish	Resin, black	
Dimensions	210 (w) x 44 (h) x 205.1 (d) mm	
Weight	700 g	

* 0 dB = 1 V

Note: The design and specifications are subject to change without notice for improvement.

• Accessories

AC-DC adapter 1

• Optional products

Mounting bracket kit: MB-WT1 (for rack mounting one WT-5800/5805 unit)
MB-WT2 (for rack mounting two WT-5800/5805 units)