

■ DESCRIPTION

The RS-160 can call and converse with the registered master stations.  
It utilizes a 2-core shielded cable.

■ SPECIFICATIONS

Rated Input	1 W
Rated Impedance	625 Ω (1 W/25 V)
Internal Speaker	4 cm cone-type
Operating Temperature	-10°C to +50°C (Temperature range not to freeze the speaker and switch)
Finish	Panel: Stainless steel (SUS304), hairline Call button: Metal
Dimensions	120 (W) × 120 (H) × 57.5 (D) mm
Weight	540 g
Accessory	Box mounting screw (No.6-32UNC × 8) .....4, Box mounting screw (M4 × 25) .....4

Maximum cable distance

Cable Type	AWG24 (ø0.52 mm)	AWG22 (ø0.65 mm)	AWG20 (ø0.82 mm)
Distance	0.5 km	0.8 km	1.3 km

■ APPEARANCE

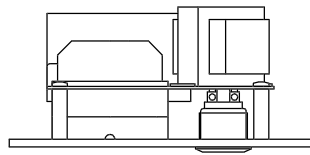

Top View

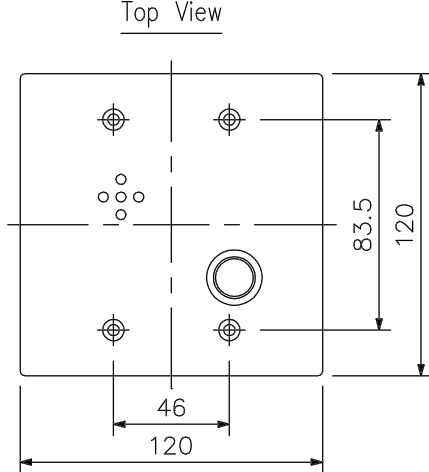

Front View

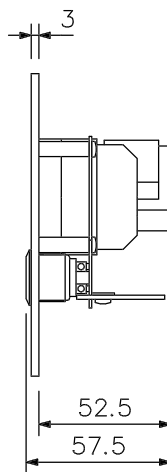

Side View

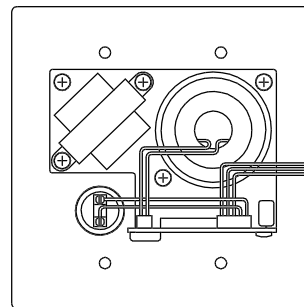

Rear View

Black (C)

Brown (B)

Orange (A)

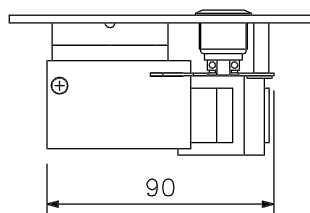

Bottom View

UNIT:mm SCALE:1/3