

DESCRIPTION

The RS-170 can call and make converse with the registered master stations.
It utilizes a 2-core shielded cable.

SPECIFICATIONS

Rated Input	1 W
Rated Impedance	625 Ω (1 W/25 V)
Internal Speaker	4 cm cone-type
Operating Temperature	-10°C to +50°C (Temperature range not to freeze the speaker and switch)
Finish	Panel: Stainless steel (SUS304), hairline Call button: Metal Printed circuit board: Weather-resistant coating
Dimensions	120 (W) × 120 (H) × 57.5 (D) mm
Weight	540 g
Accessory	Box mounting screw (No.6-32UNC × 8)4, Box mounting screw (M4 × 25)4

Maximum cable distance

Cable Type	AWG24 (ø0.52 mm)	AWG22 (ø0.65 mm)	AWG20 (ø0.82 mm)
Distance	0.5 km	0.8 km	1.3 km

APPEARANCE

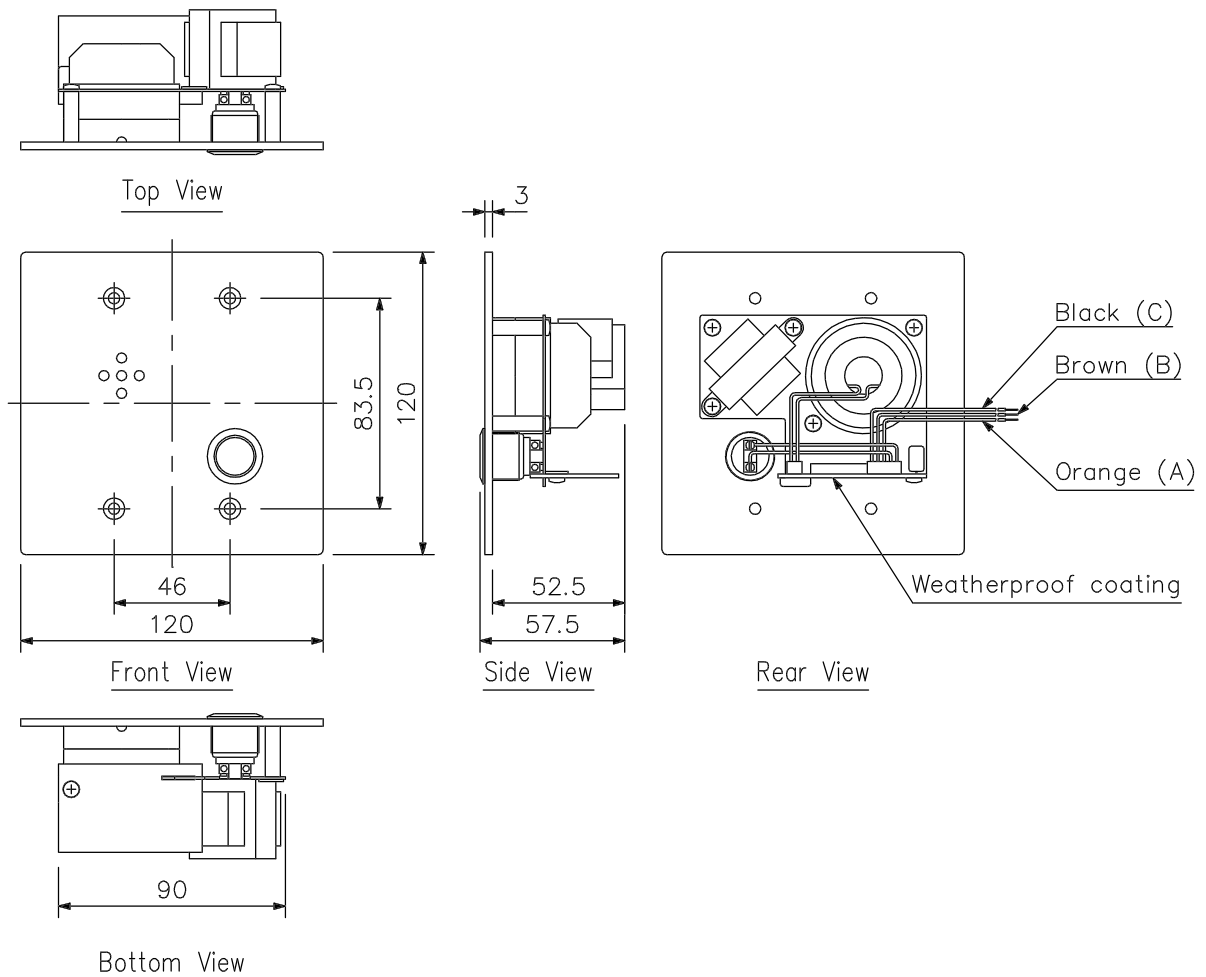

UNIT:mm SCALE:1/3