

IP-A1PC580R

IP CEILING MOUNT SPEAKER 8W



The IP-A1PC580R is a PoE-powered Ceiling Speaker with a built-in 8 W amplifier and internal data storage for up to 20 audio files. It supports SIP protocol for flexible integrations with VoIP devices, and its 20 multicast ports are available for group paging operations. It can also receive broadcasts from Video Management System using ONVIF. Device control and further system integration is accessed through remote API (HTTP/HTTPS) or local control inputs.

Key features

- 20cm (8") dual cone-type speaker with metal construction
- Receive SIP audio, ONVIF and Multicast
- Local broadcast using internal audio files
- 1 audio input (LINE/MIC selectable, phantom power On/Off)
- 8W built-in amplifier, 1 LINE audio output
- 2 control inputs and 1 control output
- HTTP/HTTPS commands (receive)
- Audio file storage (20 files, total 80MB, WAV/MP3)
- Playback programs (Repeat, Weekly Timer)
- PoE powered

Specifications

Power Source	PoE (IEEE802.3af Class 3)
Power Consumption	12.95 W (rated output) 5 W (IEC62368-1)
Amplifier Rated Output	8 W
Frequency Response	50 Hz - 16.5 kHz
Sensitivity	97 dB (1 W, 1 m)
Max. SPL	106 dB (8 W, 1 m)
Speaker Component	20 cm (8") Dual cone-type
Audio Codec	Opus, PCMU (G.711u), PCMA (G.711a), G.722
Broadcasting Mode	SIP Broadcasting/SIP calling Mode: Opus/PCMU/PCMA/G.722, P2P/SIP Server Connection Multicast Broadcasting Mode: Opus/PCMU/PCMA/G.722 Auto codec recognition, 20 ports VMS Broadcasting Mode: PCMU Internal Message Broadcasting Mode Note: Each broadcast mode can be assigned an order of priority using the Priority Setting function.
Sound Source Files	Max. 20 files (File storage capacity: 80 MB total) Supported file formats WAV file: 8/16/44.1/48 kHz sampling frequency, 8/16 bit, monoaural/stereo MP3 file: 32/44.1/48 kHz sampling frequency, 64 - 320 kbps, CBR/VBR, monoaural/stereo Repeat playback: Playcount (1 - 10 times), Duration (5 - 3600 sec) or Timer (from Start time to End time) Interval time: 0 - 99 sec, Delay time: 0 - 99 sec Trigger: Control Input or Remote API (HTTP/HTTPS)
Chime	Pre and post chime tones (applied for Incoming SIP Call and internal audio file broadcast) Preset chime tone x 5, editable tone x 2
Network I/F	100BASE-TX, Auto MDI/MDI-X, RJ45 connector
Network Protocol	IP, TCP, UDP, TLS, HTTP, HTTPS, RTP, SRTP, RTSP, RTCP, SRTCP, ARP, ICMP, IGMPv3, NTP, SIP (RFC3261), SIPS
Audio Input	1 channel, electronically-balanced, 10 k Ω LINE/MIC selectable (Rated input: LINE: 0 dB (*1), MIC: -60 dB (*1)) PAD function (-20 dB (*1), Phantom power ON/OFF (12 V DC), volume adjustable removable terminal block (6 pins)
Audio Output	1 channel, electronically-balanced, 600 Ω or less Rated output: 0 dB (*1), removable terminal block (6 pins)
Control Input	2 channels, no-voltage make contact inputs, open voltage: 5 V DC, short-circuit current: 2 mA or less, removable terminal block (6 pins)
Control Output	1 channel, open collector output, withstand voltage: 30 V DC, control current: 150 mA or less, removable terminal block (6 pins)
Indicator	STATUS (green/blue/yellow/red), LINE/MIC IN (green/red), OUTPUT (green), LINK/ACT (green)
Clock Accuracy	\pm 13 seconds per month
Time Adjustment	Manual time setting, Time adjustment by NTP server
Power Outage Protection Period	24 hours (RTC time retention, at 40 °C (104 °F))
Dimensions for Fixing Hole	Mounting hole: \varnothing 228.6 mm (9")
Speaker Mounting Method	Screw in type

Finish	Frame: Steel plate, white (RAL 9016 equivalent), paint Grill: Steel net, white (RAL 9016 equivalent), paint
Dimensions	Ø324 x 111 (D) mm (12.76" x 4.37")
Weight	1.8 kg (3.97 lb.)
Included Accessories	Pattern paper x 1, Removable terminal plug (6 pins, preinstalled on the unit) x 2, Mounting screw (5x38) x 4
Optional Accessories	HY-BC580U Back can (for UL 2043 certified installation), BB-580D Back can (for other installations), Mount rail: Q-HY-TB2

(*1) 0 dB = 1V

NOTE: Please do not install the product near heat insulation material, or cover the product with heat insulation or acoustic absorbing materials to prevent fire risk. Please do not install the product in damp or wet locations or areas with high humidity (condensing) as it may cause damage to the product.

*ONVIF is a registered trademark of ONVIF Inc.

*These specifications apply to the firmware version 3.4.0 or later. For the latest specifications and firmware, please refer to the TOA DATA Library (<https://www.toa-products.com/international/>)

PC requirements

PC Requirements

Display	1920 x 1080 resolution or greater
OS	Windows 10 Pro (64 bit edition) Windows 10 Home (64 bit edition) Windows 11 Pro Windows 11 Home
Web Browser	Google Chrome Microsoft Edge

Dimensions

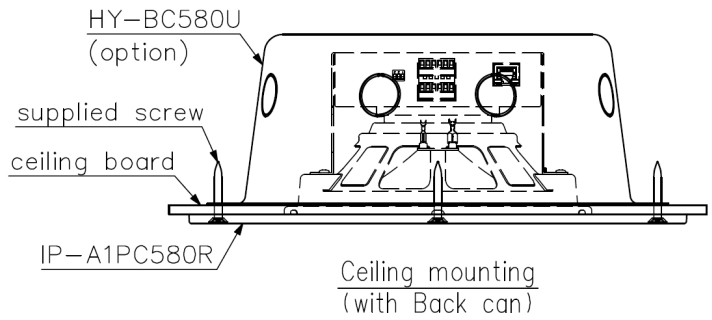
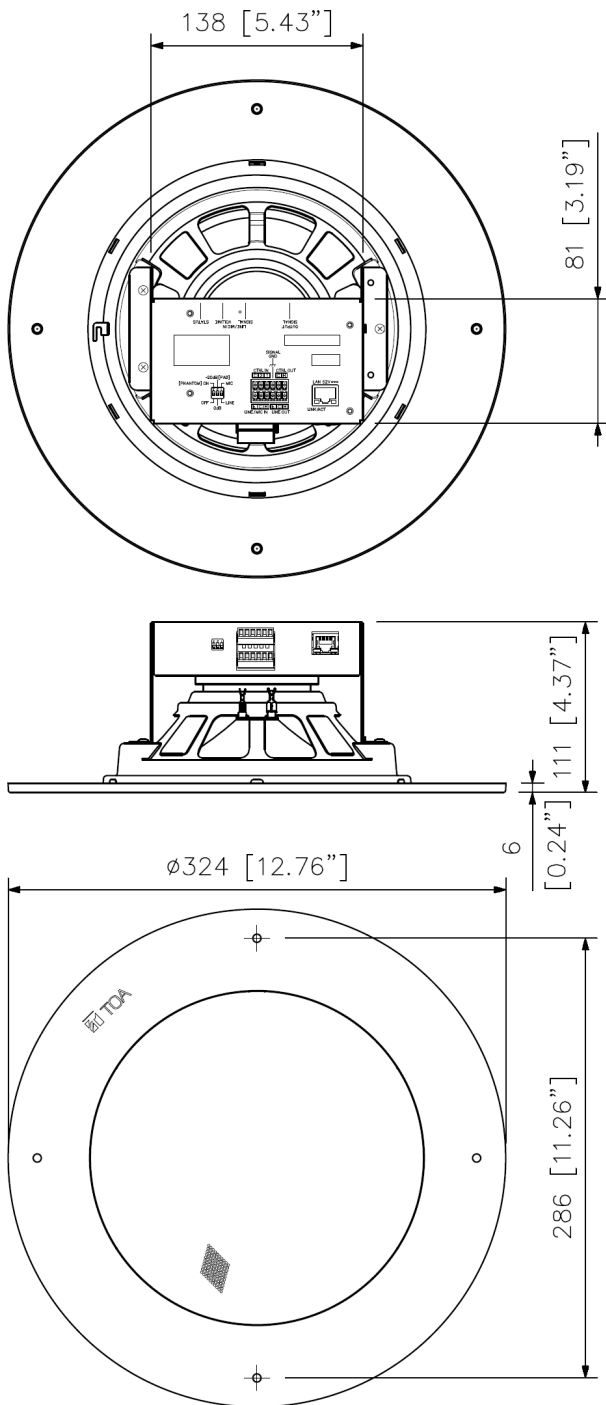

UNIT:mm

Note: Numerical values in parentheses are for reference only.

A&E specifications

The IP ceiling mount loudspeaker shall be of an in-ceiling type design, with a full robust metal construction that shall include a class D type amplifier capable of producing up to 8 watts of power. The IP ceiling mount loudspeaker shall be SIP compatible to broadcast clear and intelligible VoIP messages via a single Category 5 or greater network cable and shall support various standard network protocols and forums such as ONVIF (Open Network Video Interface Forum) and shall be able to complement VMS (Video Management System) and other audio network integration systems. Twenty multi-cast ports shall be available for group paging. The IP ceiling mount loudspeaker shall have a LINE/MIC input to accommodate an external microphone allowing the possibility to achieve two-way communication (talk-back) or other external audio devices. Switching between LINE/MIC shall be accomplished by using DIP switches. Phantom power shall be available for the microphone as well as an independent volume adjustment. The IP ceiling mount loudspeaker shall have the facility of storing up to twenty audio files with the code of WAV or MP3 format internally. The device shall have the flexibility of broadcasting these files at predetermined times by setting the start and end time along with the day(s) of the week or repeated when necessary and triggered from a control input, or remote API (HTTP). There shall be two controlled inputs and one controlled output. The IP ceiling mount loudspeaker shall be capable of being muted by TOA IP-A1PG Paging Gateway as the highest priority operation. Remote settings of the IP ceiling mount loudspeaker shall be achieved by connection to a Windows® based personal computer and by using the PC's browser, operational settings, functions and system status can be established. The loudspeaker shall incorporate a single 20 cm (8") full-range dual cone-type transducer with a smooth frequency response of 50 Hz to 16.5 kHz measured on axis with a Sound Pressure Level (SPL) of 97dB measured at 1 metre with a power input of 1 watt or 106dB with a power input of 8 watts measured at 1 metre. The power source shall be supplied from a PoE switching hub. The dimensions shall be #324 × 111 mm (d) (12.76" × 4.37") weighing 1.8 kg (3.97 lbs). The finish of the loudspeaker shall be: Baffle: steel plate, white (RAL 9016 equivalent). Grille: Steel net, white (RAL 9016 equivalent). Optional extras; Back can HY-BC580U manufactured by TOA CorporationManufacturer: TOA CorporationModel: IP-A1PC580R